

COVER
Color = Black

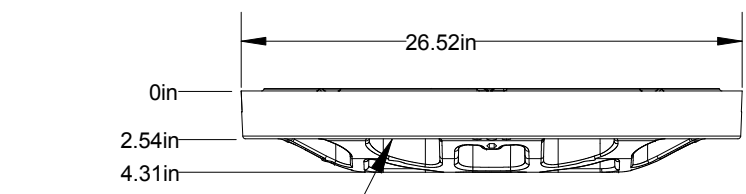

COVER SIDE

DATE OF MANUFACTURE
(MM/DD/YY FORMAT)

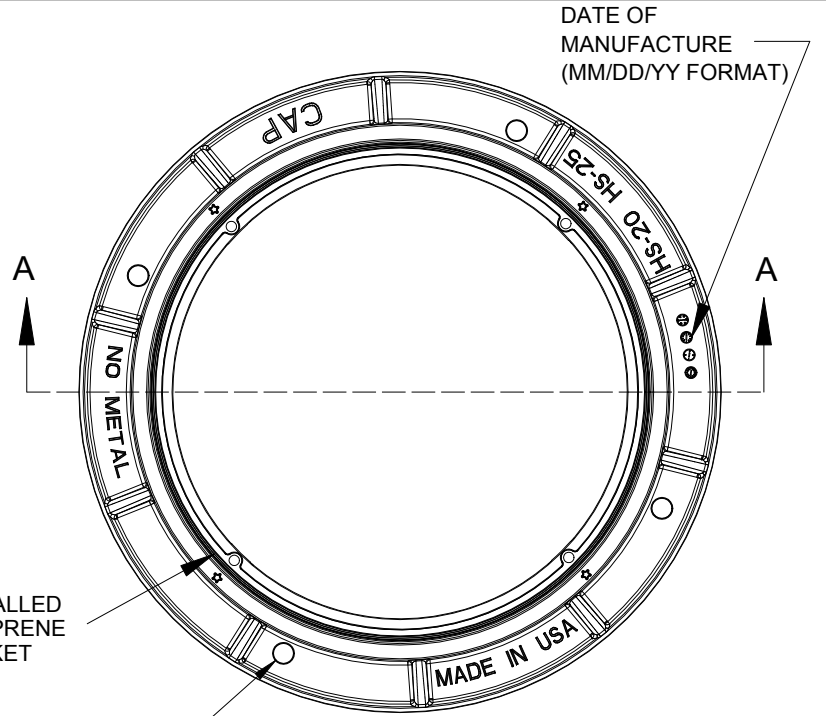

FRAME
Color = Black

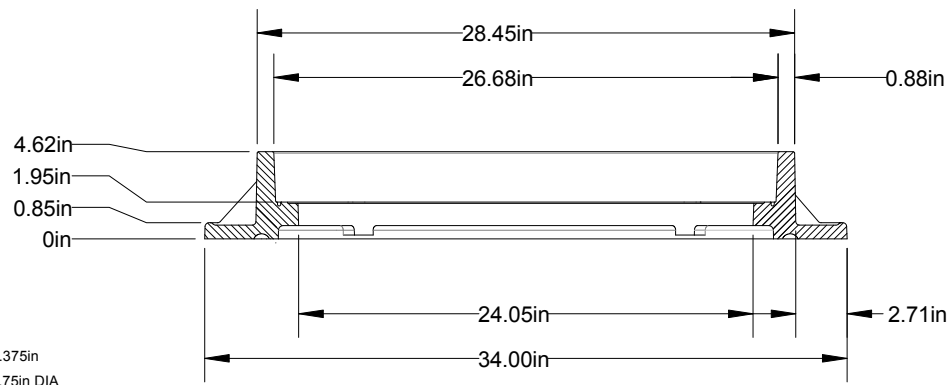

FRAME SECTION

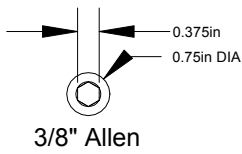

3/8" Allen

Fasteners are 1/2 -13 UNC, 3.5in long
SHCS FASTENER

1. All hardware is 316 Stainless Steel.
2. Detectable by standard metal detectors.
3. Compression Molded Thermoset Composite - no metal reinforcement
4. PASSED M306 H20/H25 PROOF LOAD
5. Watertight (0.0 GPM)



COMPOSITE ACCESS PRODUCTS

www.mmg-solutions.net

kc-sales@mmgonline.net

Product Code **A-1BK24S4-C01DMDSS-H1**

2020-09-10

Part #: CAP-24-BD-SAN