

**Water Specialties Flanged Main Line
Flow Meters
Sized 2" to 48"**

**Model MLE (ML-04)
150 psi**

DESCRIPTION

MODEL MLE AND MLF FLANGED TUBE METERS are manufactured to the highest standards. Materials used on all meters and flow ranges meet or exceed AWWA standard C704-02. The flanged end tube design permits use in a wide range of applications with up to 150 psi working pressure.

Model MLE flanged ends are 150 lb. AWWA class D flat face steel flanges.

Fabricated steel meter tubes have straightening vanes and are protected internally and externally with 12-15 mils of NSF approved, fusion bonded epoxy resin.

FEATURES

PROPELLER is magnetically coupled with the drive mechanism through the sealed oil filled gearbox. This completely eliminates water entering the meter assembly, as well as the need for any packing gland. The propeller is a conical shaped three bladed propeller, injection molded of thermoplastic material resistant to normal water corrosion and deformity due to high flow velocities.

BEARING in propeller is a water lubricated ceramic sleeve and spindle bearing system with a ceramic/stainless steel spindle. Dual ceramic thrust bearings, standard on all meters, handle flows in both forward and reverse directions. The bearing design promotes extended periods of maintenance free propeller operation. Bearings within the sealed meter mechanism are shielded precision stainless steel bearings and are factory lubricated for the life of the meter.

Indicator- Totalizer

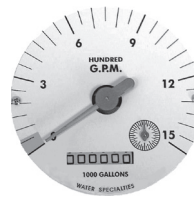

INDICATOR-TOTALIZER is mechanically driven by the meter mechanism and features a full 4" diameter, 250 degree sweep dial with a six digit, straight reading type totalizer and sweep test hand. The indicator drive mechanism is temperature compensated so the indicator will be accurate at all points on the dial when operated between 32° and 140° F. The indicator dial can be furnished in GPM, CFS, MGD or any standard liquid measuring units with choice of standard totalizer measuring units. The bonnet, with padlock hasp, is O-ring sealed to the meter head.



Part Numbers, Mechanical Registers

ML	E	XX	A	1	2	B	-	---	-	---
CONNECTION OPTIONS:										
Flanged End 150 PSI (ML03/ML04) E										
Flanged End 300 PSI (ML08) F										
METER SIZE										
2" Top Plate Meter		02								
3" Top Plate Meter		03								
4" Top Plate Meter		04								
6" Top Plate Meter		06								
8" Top Plate Meter		08								
10" Top Plate Meter		10								
12" Top Plate Meter		12								
14" Top Plate Meter		14								
16" Top Plate Meter		16								
18" Top Plate Meter		18								
20" Top Plate Meter		20								
24" Top Plate Meter		24								
30" Top Plate Meter		30								
36" Top Plate Meter		36								
42" Top Plate Meter		42								
48" Top Plate Meter		48								
Tube Options										
AWWA Class (D/F) Standard Tube Length A										
ANSI Flange (150/300) Standard Tube Length B										
Non Standard Tube X										
Propeller Options										
Standard 1										
High Velocity 2										

continued on next page



Part Numbers, Mechanical Registers

ML	E	XX	A	1	2	B	-	---	-	---
Register Options										
Totalizer 1										
Indicator/Totalizer 2										
Output Options										
No Outputs -										
4-20 Analog Only (TR15/TR16) A										
Dry Contact Pulse & 4-20 Analog (TR12 + TR16) B										
Dry Contact Pulse (TR04/TR12) C										
Register Extension Options										
Meter Mount (Standard) -										
6" Long Extension (Mech) 006										
7" Long Extension (Mech) 007										
8" Long Extension (Mech) 008										
1" Increments for Extensions Lengths XXX										
144" Maximum extension length 144										
High Temp Option										
High Temp Prop and Seals H										



SPECIFICATIONS

All specifications apply to both models MLE and MLF except where noted.

Performance

Accuracy	Plus or minus 2% of actual flow within the range specified for each meter size
Pressure Range	MLE: Up to 150 PSI maximum working pressure MLF: Up to 300 PSI maximum working pressure
Temperature Range	140° F Maximum. Consult factory for special construction for higher temperatures.
Flow Ranges	See Min-Max-Int Flow Ranges column in the table of meter specifications on page 11. <ul style="list-style-type: none"> • Size and construction are rated for continuous operation. • Min and max flow ranges will vary according to meter size and construction. • Min flow will be higher when auxiliary equipment is added. • Intermittent flow is rated for 10%-15% of the total time the meter is operating. • Consult factory for high velocity construction when intermittent flows are higher than shown in the table of meter specifications on page 11 and/or when longer operating periods are required.

Materials

Materials used in construction are chosen to minimize the corrosive effects of the liquids measured by the meter assembly.

Magnets	Anticorrosive aluminized barrier coated magnets; Everlube 6155
Interior Bearings	Shielded stainless steel
Propeller Bearing	Ceramic sleeve type
Propeller Spindle	Ceramic sleeve/stainless steel
Propeller	Injection molded thermoplastic
Gearbox	Stainless steel
Separator	Stainless steel
Shafts	Stainless steel
Meter Head Bolts	2" - 20": Stainless steel 24"-48": Plated steel
Meter Head	Cast iron or fabricated steel NSF approved, fusion bonded epoxy coated
Meter Tube	Fabricated steel with straightening vanes and coated, inside and out, with 12-15 mils of NSF approved, fusion bonded epoxy by the fluidized bed method.

Available Options

Equipment	Optional equipment is available upon request, including remote mounting kit with up to 50 feet of cable, totalizer extensions, digital transmitter, and a wide range of controls and instruments for indicating, totalizing and recording flow data for each meter. Special constructions and materials are also available upon request.
Warranty	A five-year guarantee is available for 2" - 36" meters.

MLE (ML-04) DIMENSIONS

Indicator-totalizer

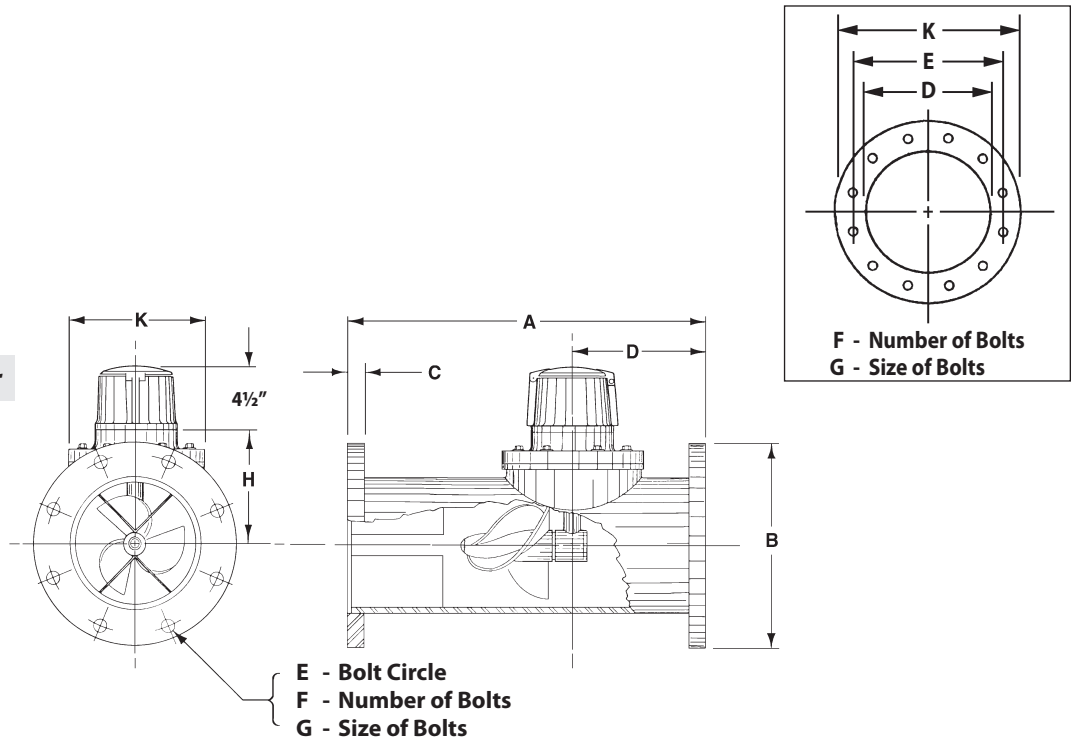

Meter & Pipe size (inches)	Flow Ranges, GPM		Dimensions									Est. Shipping Weight (lbs.)
	Flow Ranges, Standard Construction Min - Max - Int	High Velocity Construction Min - Max	A	B	C	D	E	F	G	H	K	
2	40-160-225	N/A	18	6	5/8	7	4 3/4	4	5/8	5 1/4	9	70
3	45-250-350	N/A	18	7 1/2	5/8	7	6	4	5/8	5 1/4	9	70
4	55-500-700	200-700	18	9	5/8	7	7 1/2	8	5/8	5 1/4	9	80
6	120-1200-1500	300-1500	22	11	11/16	9	9 1/2	8	3/4	6 1/4	9	150
8	150-1500-2000	400-2500	24	13 1/2	11/16	9	11 3/4	8	3/4	7 1/4	9	170
10	180-2000-3000	500-3500	26	16	11/16	10	14 1/4	12	7/8	8 1/2	11	230
12	200-3000-3500	800-5000	28	19	13/16	10	17	12	7/8	9 1/2	11	288
14	300-4000-4500	1000-6000	42	21	15/16	12	18 3/4	12	1	10 1/2	13 1/2	396
16	400-5000-6000	1200-7500	48	23 1/2	1	12	21 1/4	16	1	11 1/2	13 1/2	547
18	700-6000-7500	1500-9000	54	25	11/16	15	22 3/4	16	11/8	12 1/2	13 1/2	665
20	850-8000-9000	2000-12000	60	27 1/2	11/8	15	25	20	11/8	13 1/2	13 1/2	780
24	1000-10000-13500	3000-15000	72	32	1 1/4	18	29 1/2	20	1 1/4	17 1/2	21	1250
30	1800-15000-21000	4000-25000	84	38 3/4	13/8	18	36	28	1 1/4	20 1/2	21	2010
36	2000-20000-30000	5000-35000	96	46	15/8	20	42 3/4	32	1 1/2	23 1/2	21	2840
42	3000-30000-40000	6000-50000	96	53	1 3/4	24	49 1/2	36	15/8	28	32	4300
48	5500-35000-50000	7000-60000	96	59 1/2	17/8	24	56	44	15/8	31	32	4730

Standard construction will be supplied for all main line meters unless special flow range, materials, or construction are required.

INSTALLATION

Flanged end meters: A tube is inserted into a section of open pipe and each flanged end is joined to the existing pipe using the provided gaskets and bolts.

Plain, grooved, or threaded end meters: A tube is inserted into a section of open pipe and each end is joined to the existing pipe as appropriate to its type.

The meter can be installed horizontally, vertically, or inclined on suction or discharge lines. The meter must have a full flow of liquid for proper accuracy. Complete installation, removal, and reinstallation instructions can be found in the meter's Installation, Operation, and Maintenance Manual.

PIPE RUN REQUIREMENTS

Fully opened gate valves, fittings or other obstructions that tend to set up flow disturbances should be a minimum of ten pipe diameters upstream and two pipe diameters downstream from the meter. Installations with less than ten pipe diameters of straight pipe require straightening vanes. Meters with straightening vanes require at least five pipe diameters upstream and two pipe diameters downstream of the meter.

Configuration	A	B
Without straightening vanes	10	1
With straightening vanes	5	1

Dimension C varies depending on meter size.	
Meters 2" - 20"	8"
Meters 24" - 72"	11 1/2"

STRAIGHTENING VANES

Special attention should be given to systems using two elbows "out of plane" or devices such as a centrifugal sand separator. These cause swirling flow in the line that affect propeller meters. Well developed swirls can travel up to 100 diameters downstream if unobstructed. Since most installations have less than 100 diameters to work with, straightening vanes become necessary to alleviate the problem.

Straightening vanes will break up most swirls and ensure more accurate measurement. McCrometer actively encourages installing vanes just ahead of the meter. Straightening vanes are available in weld-in and bolt-in.

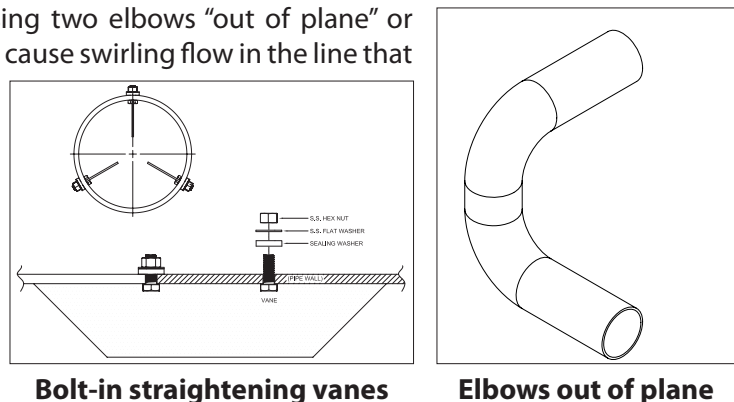

REGISTERS AND TOTALIZERS

Indicator-Totalizer

The instantaneous flow rate indicator is standard and available in gallons per minute, cubic feet per second, liters per second and other units.

The register housing protects both the register and cable drive system from moisture while allowing clear reading of the flow rate indicator and totalizer.

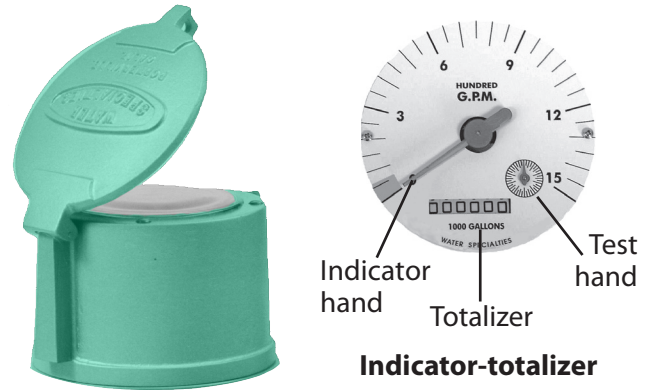

Digital Totalizer

The optional FlowCom register displays a flow meter's flow rate and volumetric total. Available are optional outputs: scaled pulse and/or industry standard 4-20mA signal. The FlowCom can be fitted to any new or existing McCrometer propeller flow meter.

Automated meter reading for the FlowCom register is available with the Smart Output transmitter option.



Wireless Telemetry

The optional FlowConnect is designed specifically for wireless telemetry via either satellite or cellular data service. Manual meter reading is never required. It uses either the mechanical register or the digital register (both shown above).

You can determine how often readings are made and transmitted to the cloud database, which you can view on a PC or on a cell phone. The viewing utility provides data tools that can analyze flow rate, consumption, and possible anomalies in an irrigation system.



Copyright © 2022 McCrometer, Inc. All printed material should not be changed or altered without permission of McCrometer. Any published pricing, technical data, and instructions are subject to change without notice. Contact your McCrometer representative for current pricing, technical data, and instructions.