



2" - 20"

ELECTRONIC

MAIN LINE METERS

MODELS:
ML04D, ML08D, ML12D, ML20D, MLI1D

INSTALLATION, OPERATION AND MAINTENANCE MANUAL

30119-05, Rev. 4.2
June 1, 2017

Contents

INTRODUCTION	1
Safety Symbols And Warnings	1
Safety Warnings	1
Uncrating.....	1
1.0 INSTALLATION.....	2
2.0 WELDING SADDLE METER PROCEDURE	2
3.0 MAINTENANCE	3
3.1 Disassembly and inspection of meter	3
3.2 Meter Head Removal*	3
3.3 Propeller Removal.....	4
3.4 Reverse Thrust Bearing Cartridge	4
3.5 Water Lubrication	4
3.6 Ceramic Bearing Cartridge.....	4
3.7 Spindle Ceramic Sleeve	5
3.8 Separators / Support Spindle Assembly.....	5
4.0 REASSEMBLING METER	5
4.1 Propeller Installation	5
4.2 Thrust Bearing Cartridge Assembly.....	5
4.3 Propeller Bearing	5
5.0 SENSOR AND FC101 DIGITAL INDICATOR TOTALIZER	6
6.0 PRIOR TO RE-INSTALLING METER	6
7.0 ORDERING PARTS OR RETURN TO FACTORY	6
8.0 RETURNING A UNIT FOR REPAIR.....	10
WARRANTY	11

INTRODUCTION

Safety Symbols And Warnings

Throughout this manual are safety warning and caution information boxes. Each warning and caution box will be identified by a large symbol indicating the type of information contained in the box. The symbols are explained below:



This symbol indicates important safety information. Failure to follow the instructions can result in serious injury or death.



This symbol indicates important information. Failure to follow the instructions can result in permanent damage to the meter or installation site.

Safety Warnings

When installing, operating, and maintaining McCrometer equipment where hazards may be present, you must protect yourself by wearing Personal Protective Equipment (PPE) and be trained to enter confined spaces. Examples of confined spaces are manholes, pumping stations, pipelines, pits, septic tanks, sewage digesters, vaults, degreasers, storage tanks, boilers, and furnaces.

You must follow all state and local laws, as well as Occupational Safety and Health Administration (OSHA) regulations concerning Personal Protective Equipment and confined-space entry. Specific requirements can be found in the OSHA section of the Code of Federal Regulations: *29 CFR, 1910.132 - 1910.140, Personal Protective Equipment; and CFR Title 29, Part 1910.146, Permit-Required Confined-Spaces.*



WARNING!

Incorrect installation or removal of meters can result in serious injury or death. Read the instructions in this manual on the proper procedures carefully.



WARNING!

Never enter a confined space without testing the air at the top, middle, and bottom of the space. The air may be toxic, oxygen deficient, or explosive. Do not trust your senses to determine if the air is safe. You cannot see or smell many toxic gases.



WARNING!

Never enter a confined space without the proper safety equipment. You may need a respirator, gas detector, tripod, lifeline, and other safety equipment.



WARNING!

Never enter a confined space without standby/rescue personnel within earshot. Standby/rescue personnel must know what action to take in case of an emergency.

Uncrating

When uncrating the meter, any damage due to rough or improper handling should be reported to the transportation firm and McCrometer. If for any reason it is determined that the unit or parts of the unit should be returned to the factory, please contact McCrometer for clearance prior to shipment. Each unit must be properly crated to prevent any further damage. The factory assumes no responsibility for equipment damage in return shipment due to improper packaging. The shipping crate contains the following items:

FC101 Digital Register

Operation and Maintenance Manual

Tool T-2402X-1

1.0 INSTALLATION



WARNING!

Before removing the meter head from the pipeline, the water must be turned off and pressure must be relieved from the line. Serious injury can result from removing a meter head under pressure.

Installation of Water Specialties Main Line Meters varies, depending upon the type and model of meter selected for each application. The meter must have a full flow of liquid for proper accuracy. The meter installations fall into three basic categories:

FLANGED TUBE METERS can be installed exactly as you would install any short length of flanged pipe. Flanged ends are standard pattern and drilling for each meter size. Fully opened gate valves, fittings, or other obstructions that tend to set up flow disturbances should be a minimum of five pipe diameters upstream and one pipe diameter downstream from the meter.

PLAIN END TUBE METERS can be installed similar to replacing a short length of plain end pipe in the line by either welding, or by using one of a variety of pipe couplings available. NOTE: Meter head assembly (#25) should be removed before welding (see Section VI Step 1). Fully opened gate valves, fittings, or other obstructions that tend to set up flow disturbances should be a minimum of five pipe diameters upstream and one pipe diameter downstream from the meter.

WELDING SADDLE METERS can be installed on an existing pipeline by cutting a hole of proper size and welding a meter saddle (furnished with the meter) to the pipe.

2.0 WELDING SADDLE METER PROCEDURE

The installation steps outlined below should be followed carefully to achieve proper mounting of the meter:

1. Align the cutout template in the desired position for the meter on the pipe. Make certain that the center line of the pipe and the center line marked on the template are parallel with each other. Some people prefer to use the saddle as the template.
2. Scribe the pipe along the line specified for your meter size cutout.
3. Cut out the section of pipe within the scribed line and remove all burrs, slag, and rough edges from the inside and outside of the cutout section.

Straightening vanes

Straightening vanes are recommended when there are less than ten pipe diameters of straight pipe (no fittings or obstructions) directly upstream from the meter location. Straightening vanes are available from the factory and, when required, should be installed in the following manner prior to welding the saddle to the pipe:

1. Hold the vanes on the outside of the pipe ten inches upstream from the center of the cutout opening. The vanes must be parallel to the center line of the pipe and should be equally spaced radially 120° apart.
2. Mark the pipe around the straightening vane bolts and drill holes for vane mounting (9/16" hole for 4-inch through 12-inch meters or 11/16" dia. hole for 14-inch through 20-inch meters).
3. Insert the vanes into the pipe through the cut-out opening after installing the brass and stainless/rubber washers over the vane bolts. The brass washer should be installed against vane bolt head with the stainless/rubber washer installed against the brass washer (rubber side away from vane). Position the vanes inside the pipe with the bolts protruding through the vane mounting bolt holes. Place stainless/rubber washers over each bolt, rubber against the pipe. The brass washer should be placed between the stainless washer and the vane mounting nut. Secure nuts to hold the vanes to the pipe (approx. 60 ft/lbs. torque). The vanes can be welded to the pipe if desired; however, the washers should not be used. NOTE: Meter head assembly (#25) should be removed before welding.

Welding Saddle

Welding saddle should be centered over the cutout section of the pipe. Make certain that no part of the pipe protrudes past the inside edge of the welding saddle. Tack weld the saddle to the pipe prior to welding a continuous bead around the saddle. NOTE: Meter head assembly (#25) should be removed before welding.

Meter Assembly

Meter assembly should be placed in the line with the propeller nose facing the upstream flow in the pipe. Use care when installing the meter not to damage the propeller as it passes through the saddle opening. The meter head O-ring should be covered with a thin coat of silicone grease before installing the meter. Tighten the meter head bolts securely.

3.0 MAINTENANCE

McCrometer products have been carefully designed to be as maintenance free as possible. Periodic preventive maintenance, however, is highly recommended and should be practiced according to schedule to assure continuous accuracy and trouble-free performance of your propeller meters. The maintenance and inspection procedure can also be used as a guide to locating a problem in the unit that may be the cause of abnormal meter operation.

Routine preventative maintenance should be performed on all meters, which includes cleaning and an inspection of the propeller and its bearing. The intervals between inspections depend on the water quality and the usage of the meter. The initial inspection should be performed after one to two years of service to determine the period between future inspections. After five to ten years, the complete meter should be inspected to ensure years of dependable service.



WORKING AREA chosen for disassembly and reassembly of the meter components should be clean to reduce the chance of dust or dirt particles being introduced into the propeller area.

3.1 Disassembly and inspection of meter

Disassembly and inspection of the meter includes cleaning the propeller assembly (#1), ceramic bearing cartridge (#8), separator/support spindle assembly (#12), and drive magnet (#9).

3.2 Meter Head Removal*

Meter head assembly (#25) should be removed from the service line by removing the meter head bolts (#24) and lifting up the rear (downstream) portion of the meter head (#25), carefully pulling the assembly back (downstream) and up at the same time to allow the propeller (#1) to clear the inside of the meter saddle and be lifted free. Inspect the meter head O-ring (#22) for any sign of damage and replace if necessary. Replace the meter assembly (#25) with a dummy cover plate if the service line is to remain in operation.

* NOTE: 8-inch meter only:

- a) Remove the meter head bolts (#24).
- b) Lift the meter assembly and tilt it forward.
- c) Slide the assembly back out of the saddle opening. The propeller may have to be rotated to fit through the saddle opening.

3.3 Propeller Removal

Propeller removal can be accomplished by first removing the thrust bearing cartridge assembly (#5). Loosen the set screw (#3) in the side of the nose of the propeller. Remove the thrust bearing cartridge (#5) by turning it counterclockwise while holding the propeller in place.

3.4 Reverse Thrust Bearing Cartridge

Reverse thrust bearing cartridge (#6) must now be removed. Turn the propeller (#1) so that the Allen wrench clearance hole is lined up with the set screw (#7) in the side of the reverse thrust bearing cartridge (#6). The location of the set screw is marked by a small hole drilled in the face of the reverse thrust bearing cartridge. With a 5/64" Allen wrench, loosen the set screw (#7) in the reverse thrust bearing cartridge (#6) one turn, which will allow the set screw to protrude about 1/32" and should allow cartridge to be unscrewed without damaging the spindle thread. NOTE: If the bearing area appears to be clogged with dirt or sediment, making it difficult to locate the set screw (#7) or to allow the Allen wrench to fit into the set screw socket, then the bearing area should be flushed out with water. Insert tool T-2402X-1 into the propeller through the threaded nose. The tabs in the tool should engage in the screwdriver slot in the end of the reverse thrust bearing cartridge (#6). Remove the propeller assembly (#1) and reverse thrust bearing cartridge (#6) by turning tool T-2402X-1 counterclockwise unscrewing the reverse thrust bearing cartridge (#6) from the spindle (#12). The propeller assembly with reverse flow cartridge will now slide off the spindle. WARNING: If the reverse thrust cartridge does not unscrew easily, it may be because the set screw was not unscrewed enough. If unscrewing of reverse flow cartridge is continued with set screw binding on spindle thread, damage to thread could occur.

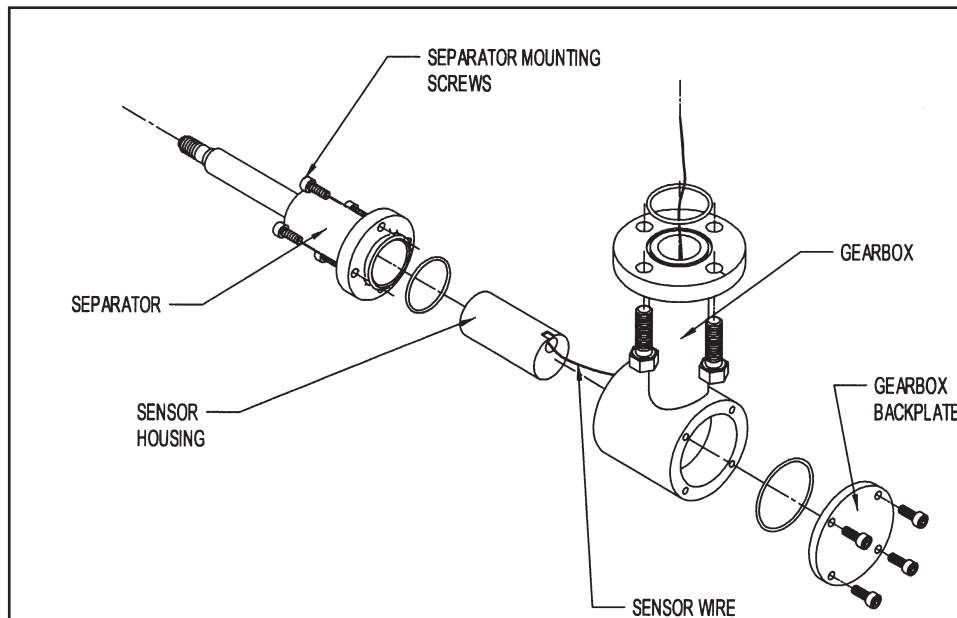

Figure 1. Exploded view of gearbox

3.5 Water Lubrication

Water lubrication of the ceramic bearing cartridge (#8) is achieved by means of two openings in the end of the thrust bearing cartridge (#5), which allow air to be purged from the bearing area. These should be cleared of any foreign material by running a small wire through the holes on either side of the screwdriver slot.

3.6 Ceramic Bearing Cartridge

Ceramic bearing cartridge (#8) and drive magnet (#9) should be cleaned of any foreign material and inspected for damage. Using a bottle brush, thoroughly clean the ceramic bearing surface (#8) and the magnet inside diameter (#9). After cleaning the propeller, flush the inside out with water. The outside surfaces of the propeller should also be cleaned to assure a smooth, unrestricted flow across the surface of the propeller. Do not use an oil based solvent in cleaning, as damage to the assembly could occur.

3.7 Spindle Ceramic Sleeve

Spindle ceramic sleeve and the O.D. or surface of the separator/support spindle (#12) should be cleaned and inspected for any substantial amount of wear (separator face is located where the propeller magnet (#9) aligns over the separator). The thrust bearing (#5) should be checked for any damage. If it is determined that the spindle ceramic sleeve or separator (#12) are worn excessively, the separator/support spindle assembly (#12) should be replaced.

3.8 Separators / Support Spindle Assembly

Separator / support spindle assembly (#12) can be removed for replacement by removing the four mounting screws (#13) which thread into the gearbox. Separator O-ring (#14) should be replaced and the new O-ring (#14) covered with a thin coat of silicone grease. The separator/support spindle assembly (#12) can then be replaced in the front of the gearbox (#16) with a firm push, gently rotating the assembly at the same time. Replace and tighten the four mounting screws (#13).

4.0 REASSEMBLING METER

4.1 Propeller Installation

- a. The reverse thrust cartridge set screw (#7) should be protruding 1/32" out of the reverse thrust cartridge so it will not bind up on the spindle thread. NOTE: Look through the hole in the reverse thrust cartridge to be sure the set screw is not protruding.
- b. Slide the propeller assembly onto the support spindle (#12) until the reverse thrust bearing cartridge (#6) contacts the threads on the end of the spindle (#12). If you feel any resistance when threading the reverse thrust cartridge on, stop at once and check to be sure the set screw is not binding on the thread. Be careful not to cross-thread the reverse thrust bearing cartridge.
- c. Thread the reverse thrust bearing cartridge on the spindle (#12) until the trailing edge of the propeller contacts the gearbox (#16).
- d. Set the proper end play by using tool T-2402X-1 to loosen the reverse thrust bearing cartridge (#6) approximately one half to one full turn counterclockwise. There should be minimal clearance between the gearbox (#16) and trailing edge of the propeller, however the propeller must not contact the gearbox. Remove tool T-2402X-1 to determine the location of the set screw in the reverse thrust cartridge and then reinsert the tool and hold it while turning the propeller until the clearance hole in the propeller lines up with the set screw in the reverse thrust bearing cartridge.
- e. Tighten the set screw (#7) in the side of the reverse thrust bearing cartridge (#6).

4.2 Thrust Bearing Cartridge Assembly

Thrust bearing cartridge assembly (#5) should be inspected for damage and replaced in the nose of the propeller. The thrust bearing cartridge (#5) is used to adjust the amount of longitudinal end play of the propeller assembly on its spindle (#12), which should be about 1/64". End play can be adjusted after the set screw (#3) in the side of the propeller (#1) is loosened by turning the thrust bearing cartridge assembly (#5) clockwise until it tightens against the end of the support spindle (#12), then turning thrust bearing cartridge (#5) counterclockwise 1/8 of a turn. Tighten set screw (#3). Check the longitudinal end play of the propeller to ensure it is not excessive and does not allow the propeller (#1) to contact the gearbox (#16). Check the clearance between the propeller (#1) and gearbox (#16). The clearance should be minimal and the propeller assembly (#1) must spin freely.

4.3 Propeller Bearing

Propeller bearing (#8) can be checked for excessive radial play by rocking the propeller (#2) gently from side to side on the spindle (#12). Some play is required for proper operation of the water lubricated ceramic sleeve bearing.

SENSOR AND FC101 DIGITAL INDICATOR TOTALIZER

5.0 SENSOR AND FC101 DIGITAL INDICATOR TOTALIZER

FC101 digital indicator (#34) should not be removed from the meter unless battery or sensor replacement is required. If the unit must be removed, proceed as follows:

FC101 (#34) can be removed from meter head by removing the four screws (#32), then slightly lifting unit up and turning over to disconnect the two-lead sensor wires from the bottom of the FC101.

Sensor housing should be removed only if replacement is necessary. The sensor can be taken out of the separator after removing the gearbox backplate (#17). Once the backplate is removed, pull the sensor wire and sensor assembly out the back of the gearbox.

Before replacing the sensor, be sure the separator is dry. Slide sensor housing and wire assembly into the separator until it stops against the inside of separator. Note: It does not make any difference what rotation position sensor is installed, however, wire must be positioned toward back (open end) of separator. Feed the sensor wire up through the gearbox and out the meter head.

Lithium battery should offer 6 to 10 years of operation. The FC101 has a low battery display that comes on when approximately six months of life is remaining. The battery should test at least 2.8 to 3.6 volts to be considered good. NOTE: Batteries should be disposed of in an environmentally safe manner.

The FC101 digital indicator-totalizer (#34) can be rotated to one of four positions for more convenient reading. Secure with four screws (#32).

6.0 PRIOR TO RE-INSTALLING METER

Propeller assembly (#1) should be dipped in water to lubricate the propeller ceramic sleeve bearing (#8). Spin the propeller gently to make certain the meter operates smoothly and no bind or drag is apparent.

FC101 (#34) and sensor (#15) should be checked to be sure they are connected and that the battery is good. Turn the propeller by hand at a consistent speed and the indicator display should display a flow rate.

Meter head O-ring (#22) should be inspected for any sign of damage and covered with a thin coat of silicone grease. The meter can now be installed in the service line. When replacing the meter on the line, make certain that the top of the welding saddle is smooth and free of any foreign material. Make certain that no foreign materials are attached to the inside of the service line pipe, as any flow disturbance or obstructions may affect the accuracy of the meter.

7.0 ORDERING PARTS OR RETURN TO FACTORY

Inspection of all meter components that may be replaced in the field has been accomplished at this point. Should any of the meter parts, upon inspection, appear to be damaged or excessively worn they must be replaced to assure proper meter operation and prevent further damage. Costs for replacement parts not covered by warranty are available by contacting the factory. If it is determined that the meter should be returned for repair, please notify McCrometer prior to shipment. Each meter must be properly packaged to prevent damage to the meter in shipment.

MAIN LINE METER INSTALLATION INSTRUCTIONS

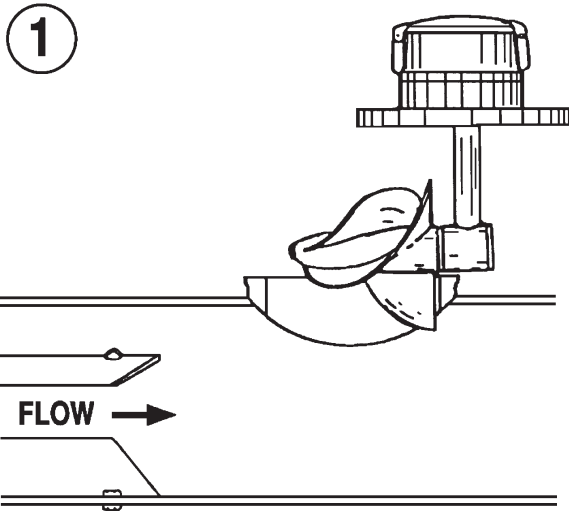

1. Set meter assembly on saddle as shown with one propeller blade pointing down. Propeller should point opposite the direction of flow.

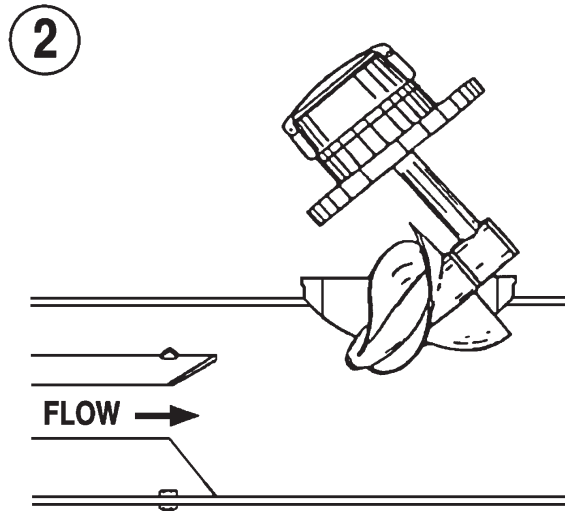

2. Tilt the meter head assembly forward allowing the propeller to move through the opening.

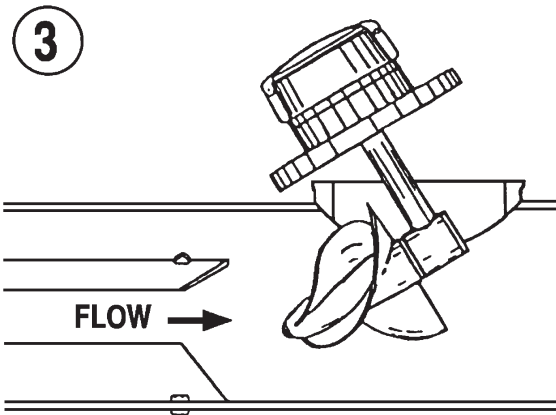

3. Slide the assembly forward and down. The propeller may have to be rotated in order to fit through the saddle opening.

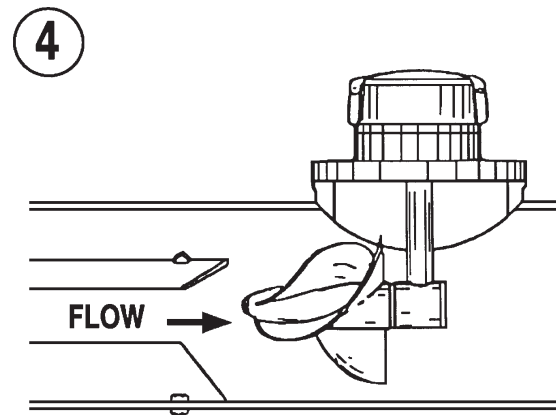

4. Allow the meter head assembly to come to rest on the saddle. Install bolts and tighten to proper torque.

SENSOR AND FC101 DIGITAL INDICATOR TOTALIZER

2"-20" ELECTRONIC MAIN LINE METERS MODELS ML04D ML08D ML12D ML20D MLI1D PARTS LIST

(Provide Meter Serial Number When Ordering Parts)

No.	QTY	Part Number	Description
none	1	7-MLI1D-*	Model MLI1D Main Line Meter Head Assembly
1	1	5-2425-‡-PT	Propeller Assembly (Items 2 thru 8)
2	1	3-2425-‡-P	Propeller
3	1	1-1125-6	Set Screw, SS Cone Point
4	1	1-1116-8-6	Screw, Bearing Cartridge Mounting
5	1	3-2356	Thrust Bearing Cartridge Assembly
6	1	3-2402-2	Reverse Thrust Bearing Cartridge Assembly (Items 6 and 7)
7	1	1-1101-8-5	Set Screw, Reverse Thrust Bearing
8	1	2-2426-P-1	Ceramic Bearing Cartridge
9	1	2-1601-2	Drive Magnet
10	1	1-2428-‡	Drive Magnet Retaining Plate
11	2	1-1115-3-18	Screw, Magnet Retaining Plate (each)
12	1	4-2455-2-D	Separator/Support Spindle Assy
13	4	1-1103-8-7	Screw, Separator/Spindle Mounting (each)
14	1	1-1551-24	O-ring, Separator
15	1	4-2730-3-‡	Sensor Housing, Sensor and Wire Assembly
16	1	3-2394-*-304	Gearbox
17	1	2-2931-SS	Gearbox Backplate
18	1	1-1551-2	O-ring, Gearbox Backplate
19	4	1-1103-8-7	Screw, Gearbox Backplate Mounting (each)
20	4	1-1251-5-12	Bolt, Gearbox Mounting (each)
21	1	10110-10	O-ring, Gearbox
22	1	1-1552-‡‡	O-ring, Meter Head
23	8	1-1301-14	Washer, Meter Head Bolt (each)
24	8	1-1251-8-24	Bolt, Meter Head (each)
25	1	3-2101-‡	Meter Head (Sizes 2" thru 12")
25	1	2-2101-14	Meter Head (Sizes 14" thru 20")
30	1	1-1707-18 1-1707-19	In Line Terminal, 2 Wire Terminal for Remote, 3 Wire
31	1	1-1551-38	O-Ring - 243 Buna
32	4	10605	Screw 10-32 x 1.25" Long
33	1	FC101-M	Magnet Wand
34	1	FC101-*	FC101 Flowcom Ind.-Tot. & Bonnet Complete - See IOM Manual
none	1	10015-00K	Desiccant Bag

* INSERT METER SIZE TO COMPLETE PART NUMBER - FOR EXAMPLE:

INSERT -02 FOR 2", -04 FOR 4", -06 FOR 6", ETC.

** USE 4" WHEN ORDERING SIZES 2" THRU 4"

‡ CONSULT FACTORY TO COMPLETE PART NUMBER

‡‡ 2" - 8" INSERT -1, 10" - 12" INSERT -2, 14" - 20" INSERT -3

Note: References to 26-29 not used.

SENSOR AND FC101 DIGITAL INDICATOR TOTALIZER

***MODEL FC101 DIGITAL INDICATOR-TOTALIZER ASSEMBLY**

***CERAMIC BEARING CARTRIDGE PROPELLER**

***ONE PIECE SEPARATOR/SPINDLE AND**

THREADED REVERSE THRUST BEARING CARTRIDGE

References to 26-29 not used.

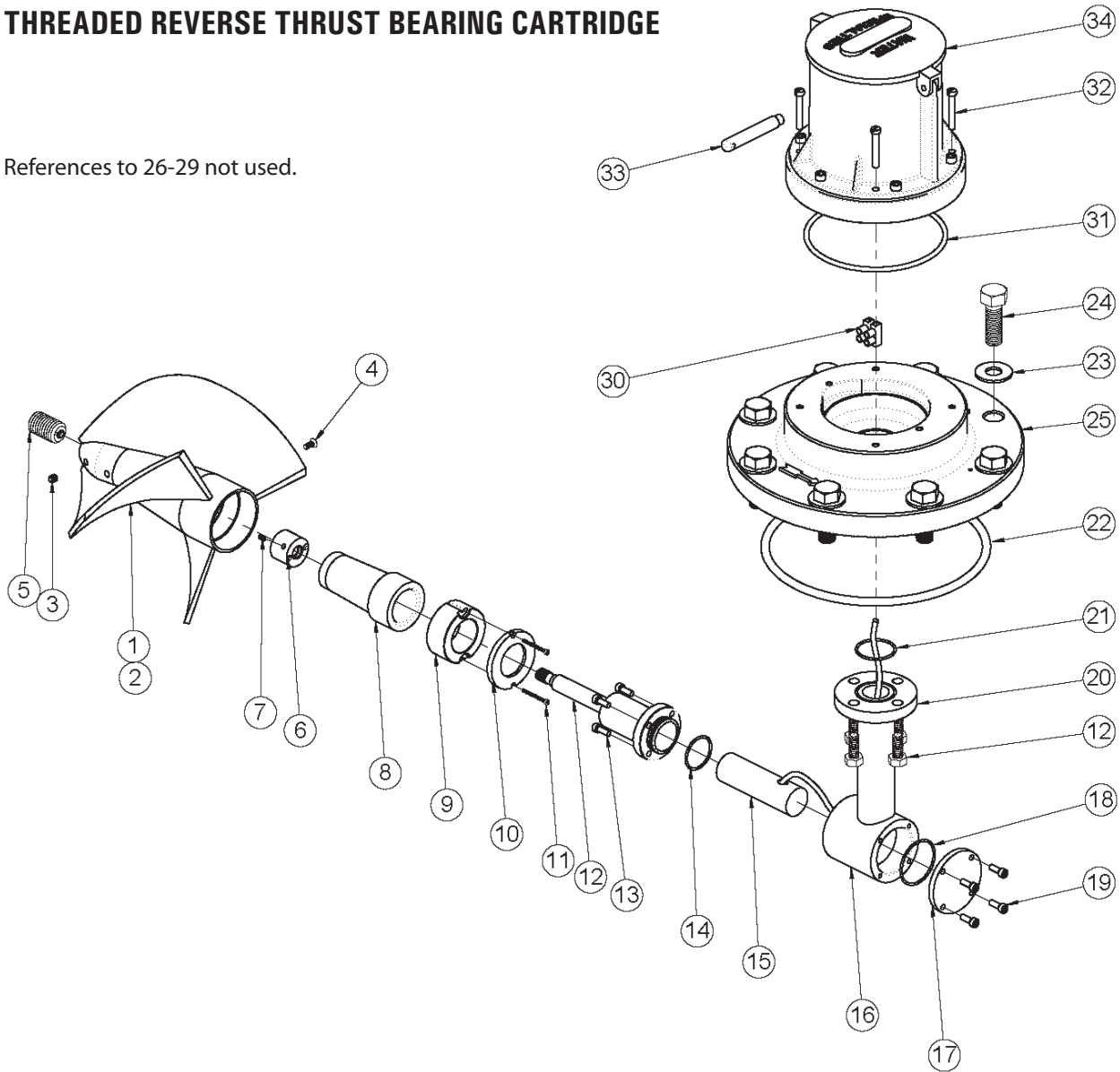

8.0 RETURNING A UNIT FOR REPAIR

If the unit needs to be returned to the Factory for repair, please do the following:

- Prior to calling for a return authorization number, determine the model number, serial number (located inside the front panel of converter), and reason for return.
- Call the McCrometer Customer Service Department and ask for a Return Authorization (RA) number.
- Ship the meter in the original packaging, if possible. Do not ship manuals, power cords, or other parts with your unit unless required for repair.
- Please make sure the meter is clean and free from foreign debris prior to shipping.
- Write the RA number on the outside of the shipping box. All return shipments should be insured.
- Address all shipments to:

McCrometer, Inc.
RMA #
3255 W. Stetson Avenue
Hemet, CA 92545

WARRANTY

This Warranty shall apply to and be limited to the original purchaser consumer of any McCrometer product. Meters or instruments defective because of faulty material or workmanship will be repaired or replaced, at the option of McCrometer, free of charge, FOB the factory in Hemet, California, within a period of one (1) year from the date of delivery.

Repairs or modifications by others than McCrometer or their authorized representatives shall render this Warranty null and void in the event that factory examination reveals that such repair or modification was detrimental to the meter or instrument. Any deviations from the factory calibration require notification in writing to McCrometer of such recalibrations or this Warranty shall be voided.

In case of a claim under this Warranty, the claimant is instructed to contact McCrometer, 3255 W. Stetson Ave., Hemet, California 92545, and to provide an identification or description of the meter or instrument, the date of delivery, and the nature of the problem.



The Warranty provided above is the only Warranty made by McCrometer with respect to its products or any parts thereof and is made expressly in lieu of any other warranties, by course of dealing, usages of trade or otherwise, expressed or implied, including but not limited to any implied warranties of fitness for any particular purpose or of merchantability under the uniform commercial code. It is agreed this Warranty is in lieu of and buyer hereby waives all other warranties, guarantees or liabilities arising by law or otherwise. Seller shall not incur any other obligations or liabilities or be liable to buyer, or any customer of buyer for any anticipated or lost profits, incidental or consequential damages, or any other losses or expenses incurred by reason of the purchase, installation, repair, use or misuse by buyer or third parties of its products (including any parts repaired or replaced); and seller does not authorize any person to assume for seller any other liability in connection with the products or parts thereof. This Warranty cannot be extended, altered or varied except by a written instrument signed by seller and buyer.

This Warranty gives you specific legal rights, and you may also have other rights which vary from state to state.

McCrometer reserves the right to make improvements and repairs on product components which are beyond the Warranty period at the manufacturer's option and expense, without obligation to renew the expired Warranty on the components or on the entire unit. Due to the rapid advancement of meter design technology, McCrometer reserves the right to make improvements in design and material without prior notice to the trade.

All sales and all agreements in relation to sales shall be deemed made at the manufacturer's place of business in Hemet, California and any dispute arising from any sale or agreement shall be interpreted under the laws of the State of California.

OTHER McCROMETER PRODUCTS INCLUDE:

	Propeller Flowmeters
	Propeller Flowmeters
	Magnetic Flowmeters
	Magnetic Flowmeters
	Magnetic Flowmeters
	Magnetic Flowmeters
	Magnetic Flowmeters
	Wireless Monitoring Systems
	Differential Pressure Flowmeters
	Differential Pressure Flowmeters
	Differential Pressure Flowmeters

FOR MORE INFORMATION CONTACT: