

Megatite[®]

SERVICE FITTINGS



Kansas City, MO
816.746.6669
kc-sales@mmgonline.net



MCINTIRE MANAGEMENT GROUP
D & W SYSTEMS SALES

Clinton, MS
601.924.5522
ms-sales@mmgonline.net



Megatite®

Making waterworks easy and accessible

Backed by 100 years of industry experience, USC is dedicated to providing high-quality products for the water and sewer industry.

The New Megatite simple push-fit removable connection is the first corrosion resistant nylon composite fitting offered for the water service industry with a lifetime warranty. The design is exclusively made to meet and exceed the standards of the water industry today and in the future.



EASY TO INSTALL



RESISTANT TO CORROSION



COST EFFECTIVE



LIFETIME WARRANTY



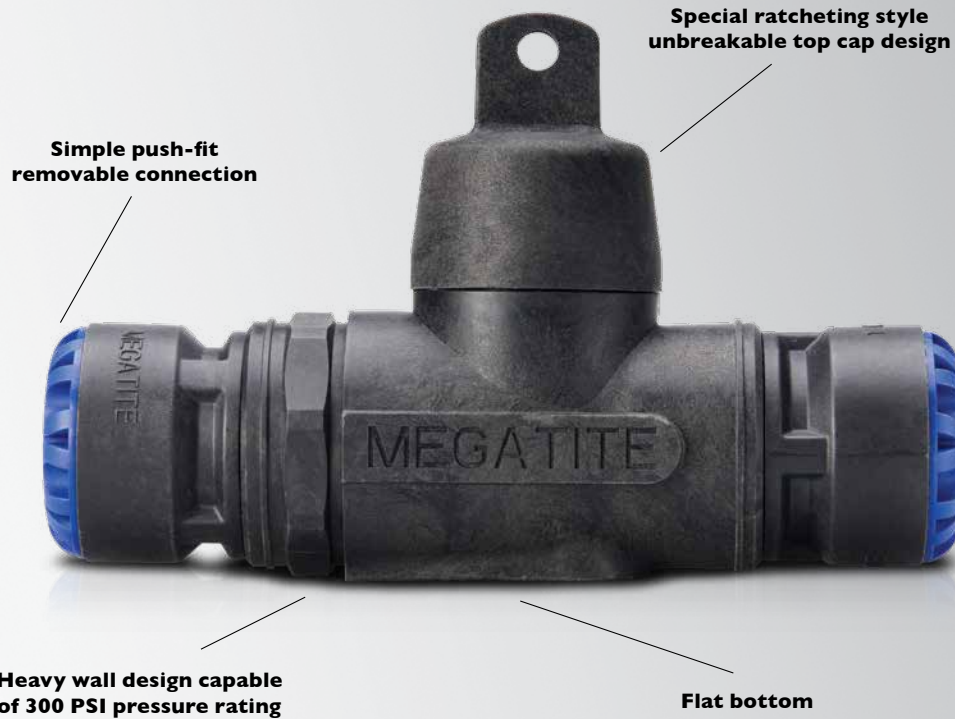

Key Features

- Material in contact with the waterway is NSF-61 approved including the NBR seals
- Body is rated for 300 PSI water, with a 2 to 1 safety factor
- All components are corrosion resistant high strength nylon composite material
- Non-breakable anti-over rotation (ratchet-style) operating cap
- Use with a standard curb box and rods
- Lifetime warranty
- Easy to install and cost effective

Benefits

- Push-fit positive stop connection for all copper tube size plastic pipes (no wrench needed)
- Full flow waterway
- Engineered flat bottom design allows for proper nesting of valve
- Heavy cross pattern design to withstand the toughness required on a contractor jobsite
- Designed for all North American climates

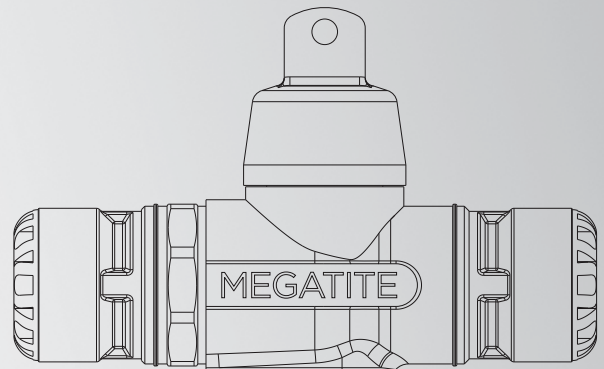

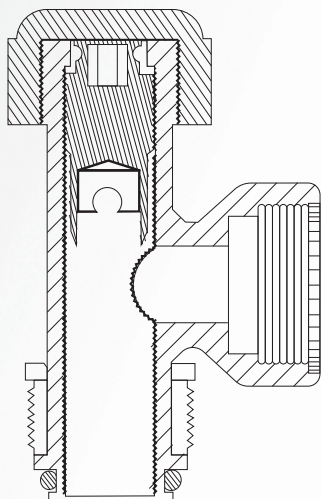

Key Features

- The Tapper is designed as a cutting and mainline isolation valve all built into one piece
- Material in contact with the waterway is NSF-61 approved material including the NBR seals
- Body is rated for 300 PSI water, with a 2 to 1 safety factor
- All components are corrosion resistant high-strength nylon composite material
- 304 stainless steel cutter with retaining rings inside the blades to retain coupon permanently
- Lifetime warranty
- Easy to install and cost effective
- Comes factory assembled with a Saddle for ease of installation and to eliminate any leaking between the Tapper and Saddle connection (see pg. 6)

Benefits

- Stainless steel cutter for PVC and HDPE pipe incorporated into the Tapper that doubles as a shut-off device
- The speed of the cutter is controlled by the internal tread design, not allowing the operator to force the cutter through the pipe
- One time use, assuring the cutter is always sharp and no need to re-sharpen
- Push-fit positive stop connection for all copper tube size plastic pipes (no wrench needed)
- Full flow waterway
- Heavy cross pattern design to withstand the toughness required on a contractor jobsite
- Designed for all North American climates
- Rotating design allowing the operator to position the Tapper outlet in the direction of the service connection

**Corrosion resistant high-strength
nylon composite material**



**Push-fit positive
stop connection**

Key Features

- Material in contact with the waterway is NSF-61 approved including the NBR seals
- Body is rated for 300 PSI water, with a 2 to 1 safety factor
- All components are corrosion resistant high-strength nylon composite material
- Lifetime warranty
- Easy to install and cost effective

Benefits

- Push-fit positive stop connection for all copper tube size plastic pipes (no wrench needed)
- Full flow waterway
- Removable end connection if required
- Designed for all North American climates

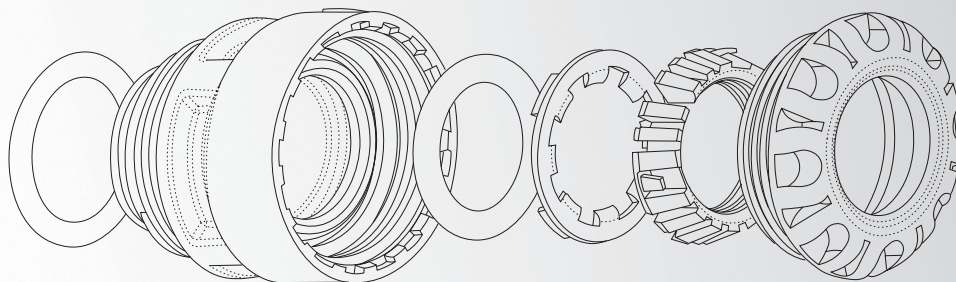

The Megatite® System

A simpler, more efficient way to connect water tubing.

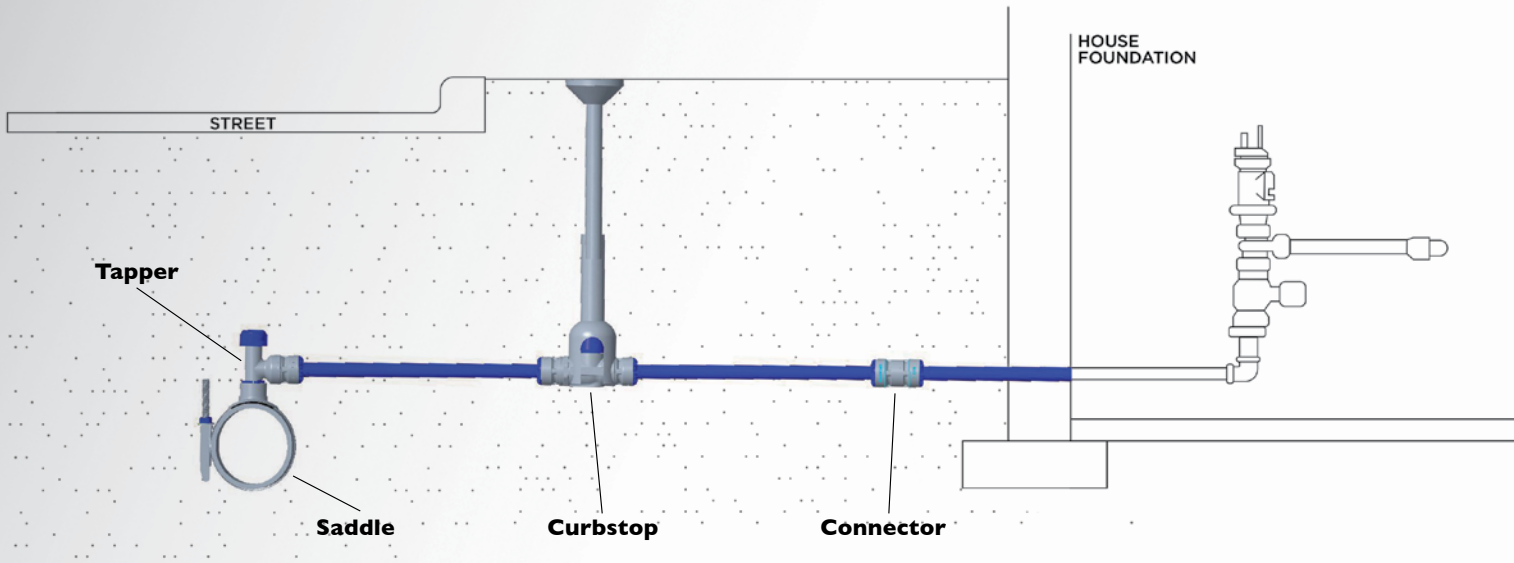

The **Megatite Tapper** and **Saddle** are supplied as a factory-assembled unit. This allows for quick and seamless installation.



USC. A solution that fits.

With over 100 years' experience, USC has been working alongside Municipalities, Engineers and distributors to help them make the right decisions for their water and sewer projects by offering better solutions for design applications.

A century of experience designing, manufacturing and making strides in the water service industry.

SAMPLE SPECIFICATION

All service fittings will be made of non-corrosive high-strength nylon composite material capable of 300 PSI. Materials of construction will be NSF-61 approved for potable water and offer a lifetime warranty. All Tappers, Curbstops and Couplings will be supplied with the Megatite push-fit designed connection for CTS size plastic tubing with pull-out strength. The slab-fit joint is rated greater than the elongation strength of the pipe in both 3/4" and 1" size. All seals will be a NBR rubber suitable for chlorinated water and provide a water-tight seal. All fittings will be Megatite or approved equal.

Tapper is supplied with an all-stainless steel 18-gauge factory assembled Saddle. Tapper body will be made of a high-strength nylon material and supplied with the Megatite end connection. Tapper cutter will be made of 304 stainless steel with an O-ring seal design and reverse internal treads to retain pipe coupon. Tapper will be Megatite by USC or approved equal.

Curbstop body will be made of a high-strength nylon composite material and supplied with the Megatite end connection capable of 300 PSI. Material will be NSF-61 approved for potable water. The operating cap will be designed with a ratcheting style action if over-torqued to stop. All valves will be factory tested providing a water-tight seal of the end bodies. All fittings will be Megatite or approved equal.

Kansas City, MO

816.746.6669

kc-sales@mmgonline.net



**MCINTIRE MANAGEMENT GROUP
D & W SYSTEMS SALES**

Clinton, MS

601.924.5522

ms-sales@mmgonline.net