

ProComm Electromagnetic Flow Meter Converter

Installation, Operation and Maintenance Manual



Standard Model

For use in non-hazardous locations

HL Model

For use in hazardous locations:

- Class I, Division 2, Groups A-D, T5
- Class I, Zone 2 IIC T5



30124-60 Rev. 1.7
October 26, 2022



Table of Contents

SAFETY	1
Safety Symbols.....	1
Safety Warnings.....	1
1.0 CONVERTER DESCRIPTION	2
2.0 INSTALLING THE CONVERTER AND CABLES	2
2.1 Verify Serial Numbers.....	2
2.2 Mounting the Converter.....	3
2.3 Installing Cables through Cable Glands and Conduit.....	4
2.4 Cable Gland Assignment for Wiring Harnesses.....	5
2.5 Pulling Sensor Cable Through Electrical Conduit.....	6
3.0 CONNECTING WIRES TO TERMINALS	7
3.1 Terminal Block Diagram.....	7
3.2 Wiring Diagrams.....	8
3.3 4-20mA Hook-Up.....	9
3.4 Opto-Isolated Pulse Output Hook-Up.....	10
3.5 Opto-Isolated Input.....	10
3.6 Optional Smart Output Hook Up.....	11
3.7 Converter Power Wiring Diagram.....	11
4.0 CONVERTER OPERATION	12
4.1 Starting up the Converter.....	12
4.2 Menu Navigation.....	12
4.3 Front Panel Display.....	13
4.4 Menu Structure.....	15
4.5 Factory Set Key Code.....	16
4.6 Converter Access Code.....	16
4.7 Changing Settings on the Quick Start Menu.....	17
4.8 Changing Main Menu Settings.....	18
5.0 MENU DESCRIPTIONS	19
5.1 Menu 1 - Sensor.....	19
5.2 Menu 2 - Units.....	21
5.3 Menu 3 - Scales.....	22
5.4 Menu 4 - Measure.....	24
5.5 Menu 5 - Alarms.....	26
5.6 Menu 6 - Inputs.....	27
5.7 Menu 7 - Outputs.....	29
5.8 Menu 8 - Communication.....	31
5.9 Menu 9 - Display.....	32
5.10 Menu 10 - Data Logger.....	32
5.11 Menu 11 - Functions.....	35
5.12 Menu 12 - Diagnostic.....	35
5.13 Menu 13 - System.....	36
6.0 BIV (BUILT-IN VERIFICATION)	37
6.1 Functioning.....	37
6.2 Saving Reference Values (Characteristic Parameters).....	37
6.3 Criteria and Internal Limits Values.....	37
6.4 General Notes for the Activation of BIV.....	37
6.5 ISOBIV Interface.....	38
7.0 ERROR CODES	39
8.0 ALARM MESSAGES	40
9.0 SPECIFICATIONS	42
10.0 DIMENSIONS	44
11.0 RETURNING A UNIT FOR REPAIR	46
12.0 TROUBLESHOOTING GUIDE	47
WARRANTY	48

SAFETY

Safety Symbols

Throughout this manual are safety warning and caution information boxes. Each warning and caution box will be identified by a large symbol indicating the type of information contained in the box. The symbols are explained below:

Safety Warnings



This symbol indicates important safety information. Failure to follow the instructions can result in serious injury or death.



This symbol indicates important information. Failure to follow the instructions can result in permanent damage to the meter or installation site.

When installing, operating, and maintaining McCrometer equipment where hazards may be present, you must protect yourself by wearing Personal Protective Equipment (PPE) and be trained to enter confined spaces. Examples of confined spaces are manholes, pumping stations, pipelines, pits, septic tanks, sewage digesters, vaults, degreasers, storage tanks, boilers, and furnaces.



WARNING!

Incorrect installation or removal of FPI Mag meters can result in serious injury or death. Read the instructions in this manual on the proper procedures carefully.



WARNING!

Never enter a confined space without testing the air at the top, middle, and bottom of the space. The air may be toxic, oxygen deficient, or explosive. Do not trust your senses to determine if the air is safe. You cannot see or smell many toxic gases.



WARNING!

Never enter a confined space without the proper safety equipment. You may need a respirator, gas detector, tripod, lifeline, and other safety equipment.



WARNING!

Never enter a confined space without standby/rescue personnel within earshot. Standby/rescue personnel must know what action to take in case of an emergency.



WARNING!

Pressurized pipes should only be hot tapped, cut, or drilled by qualified personnel. If possible, depressurize and drain the pipe before attempting any installation.



WARNING!

Carefully read all safety warning tags attached to the meter.



At the end of its lifetime, this product shall be disposed of in full compliance with the environmental regulations of the state in which it is located.

1.0 CONVERTER DESCRIPTION

Read this entire manual prior to installation and/or changing any settings. Retain this manual in your records, DO NOT DISCARD.

The signal converter is the reporting, input and output control device for the sensor. The converter allows the measurements, functional programming, control of the sensor and data recording to be communicated through the display and inputs & outputs. The microprocessor-based signal converter has a multi-point curve-fitting algorithm to improve accuracy, dual 4-20mA analog outputs, an RS485 communication port, an 8-line graphical backlit LCD display with six-key touch programming, and a rugged enclosure that meets IP67. In addition to a menu-driven self-diagnostic test mode, the microprocessor continually monitors the converter's functionality. The converter will output rate of flow and total volume. The converter also comes standard with password protection and many more features.

2.0 INSTALLING THE CONVERTER AND CABLES

2.1 **Verify Serial Numbers**

The converter and sensor are supplied as a matched system. Verify the meter serial numbers on both the converter and sensor match. This will ensure a properly calibrated system.

The tag on the side of the converter has the converter model Number, the converter serial number, the converter model number and the sensor model number. An example is shown below as Figure 1.



Meter mount converter

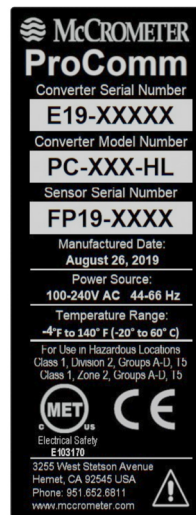

Remote mount converter

Figure 1. Converter Serial Number Tag



IMPORTANT: Verify the meter serial numbers on both the converter and sensor match. This will ensure a properly calibrated system. The meter serial number is located on the side of the sensor, and the converter serial number and the meter serial number are located on a label on the side of the converter. Ensure the meter serial number on the sensor and the converter tags match.

2.2 Mounting the Converter

Note: This applies to the remote mount converter only.

If possible, mount the converter in an electronics shed or environmental enclosure. The sun shield should be oriented in a direction to reduce sun damage and ensure readability.

Mount the converter to a solid surface using four bolts (Figure 2) or to a vertical or horizontal post using two clamps (Figure 3 and Figure 4). This electronic unit is rated IP67 for temporary flooding.

If the brackets are not attached, attach them with the four screws.

Mount the converter to a solid surface with four bolts through the holes in the left and right brackets.

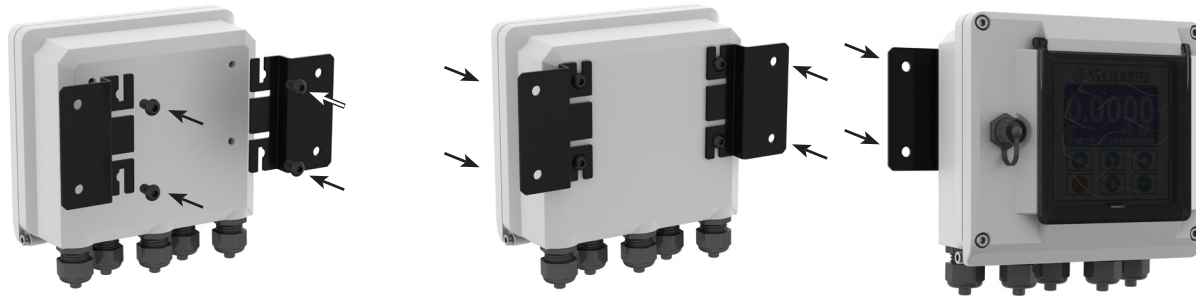

Figure 2. Mounting converter to solid surface

Remove brackets, reverse them, and reattach as shown.

Open clamps and attach around post. Slide bracket tabs onto clamps and tighten them.



Figure 3. Mounting converter to vertical post

Remove brackets, reverse them, and reattach as shown.

Open clamps and attach around post. Slide bracket tabs onto clamps and tighten them.



Figure 4. Mounting converter to horizontal post

2.3 Installing Cables through Cable Glands and Conduit

All electrical cables enter the converter through compression fittings or optional customer-supplied conduit located on the side or bottom of the converter (Figure 5, Figure 6, Figure 7). Ensure that all compression glands are properly tightened and all unused fittings are plugged so the case remains sealed.

The power cable and wiring harnesses are each assigned specific cable glands where they will pass through into the converter. See section 2.4 for cable gland assignment for wiring harnesses and section 3.2 for wiring diagrams.

All cable compression glands must be properly tightened to prevent moisture intrusion and maintain the IP67 rating. To insure IP67 rating, use only round cable 0.24" to 0.47" in diameter.



Figure 5. Remote mount converter with five cable gland pass-throughs



Figure 6. Remote mount converter with three conduit pass-throughs



Figure 7. Meter mount converter with three cable gland pass-throughs



Attaching conduit directly to the enclosure may introduce dangerous gasses and moisture into the enclosure creating a dangerous condition, and will remove the enclosure's IP67 rating. **Damage caused by attaching conduit to the enclosure or altering the enclosure in any way is not covered by the warranty.**



IMPORTANT: Do not cut or alter the cable length on power or signal cables! Connections to the sensor must be made with cable supplied by McCrometer specifically for that purpose. Do not substitute the supplied cable with other types of cable, even for short runs. For repairs or added lengths of cable, the entire cable between the sensor and the converter must be replaced. (Consult factory for replacement cable.)

2.4 Cable Gland Assignment for Wiring Harnesses

To prevent signal interference and to keep the wiring organized, each cable gland is assigned for a specific wiring harness. Refer to the assignment diagrams (Figure 8, Figure 9) below when you route your cable run.

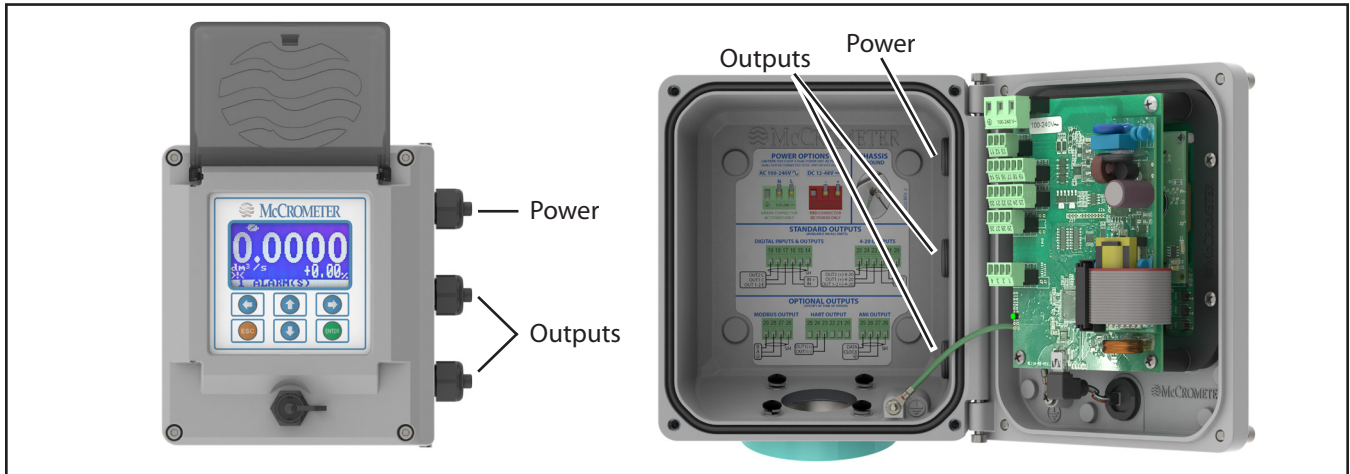

Figure 8. Meter mount converter cable assignments

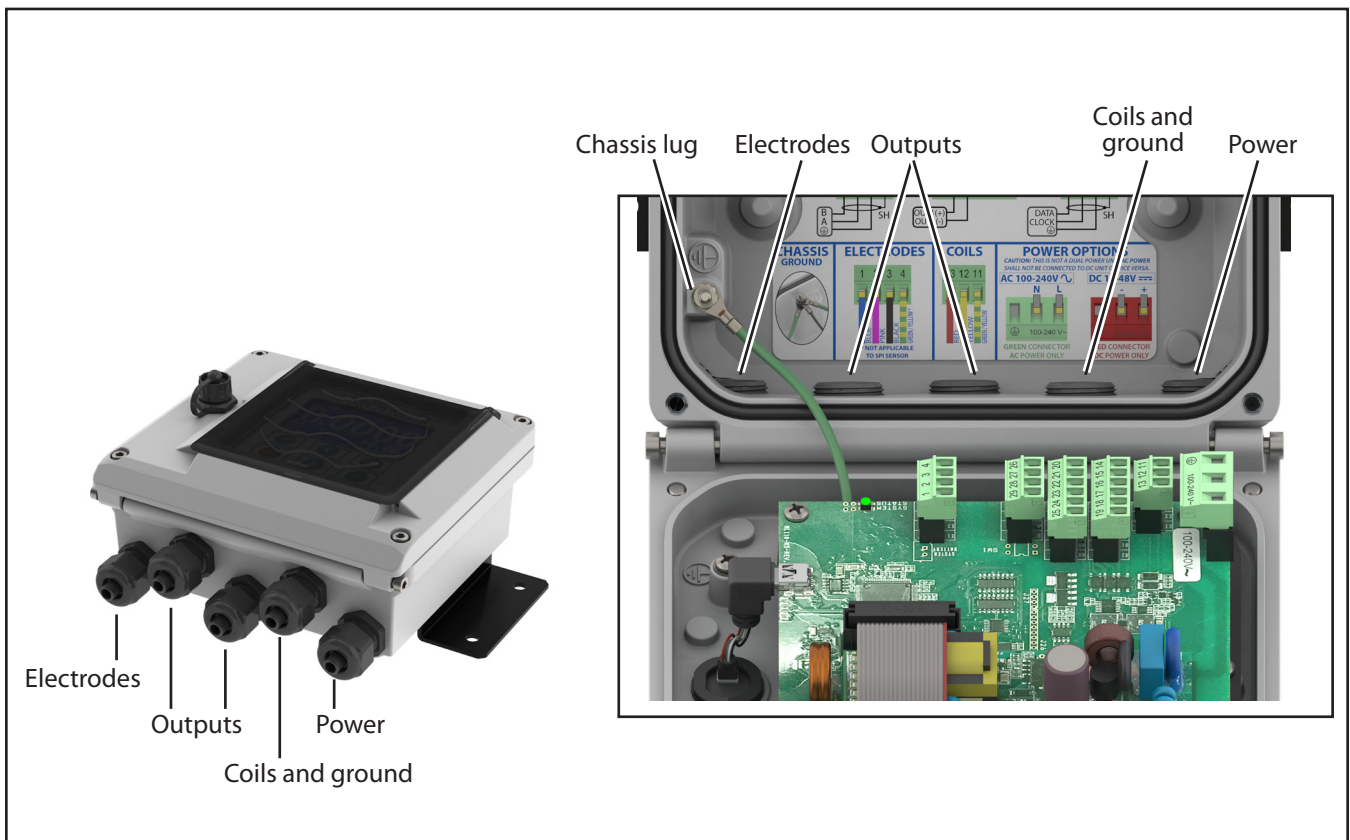

Figure 9. Remote mount converter cable assignments

2.5 Pulling Sensor Cable Through Electrical Conduit

It is very important to protect the end of the sensor cable when pulling it through a conduit. Water can accumulate in low portions of conduit. Always use a cable cover, or similar method, to seal the end of the cable against water when pulling the cable through conduit (see Figure 10). This will ensure proper operation of the meter.

NOTE Cable cover is not provided.

1. Tie a rope or cable-snake securely around the middle of the cable cover.
2. Carefully pull the rope or snake until the sensor cable end clears the conduit.
3. Bring the cable end to the converter location. If necessary, secure the cable so that it does not fall back through the conduit.
4. Remove the cable cover by pulling the rip wire. The cable cover will tear off (discard the cover).

I CAUTION: Do not cut the cable cover off. Doing so may damage the sensor cable and adversely effect the calibration of the meter.

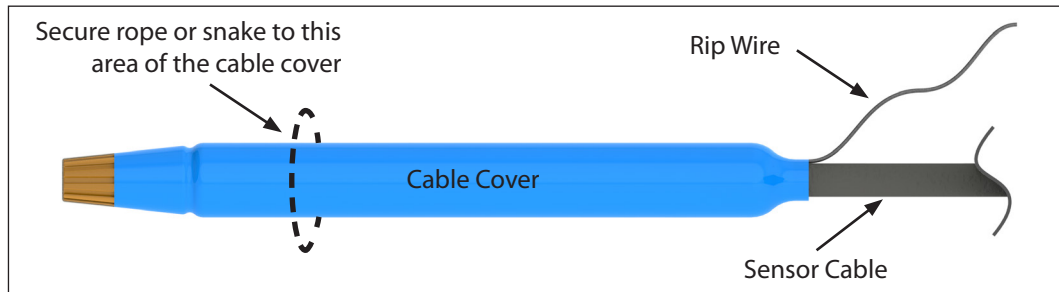

Figure 10. Cable Cover

3.0 CONNECTING WIRES TO TERMINALS



WARNING!

Ensure device is disconnected or circuit breaker is open per the requirements of IEC 60947-1 and IEC 60947-3 before opening the opening the converter.

3.1 Terminal Block Diagram

All connections are made on the terminal blocks. To access the terminal blocks, loosen the four screws on the front of the converter and open the front panel. Refer to Figure 6 and Figure 7. The example shown below (Figure 11) does not necessarily represent all converter models, however, it shows the placement for all terminal blocks used in all models.

NOTE: The terminal blocks unplug from the circuit board for easy connection.

Remote mount view

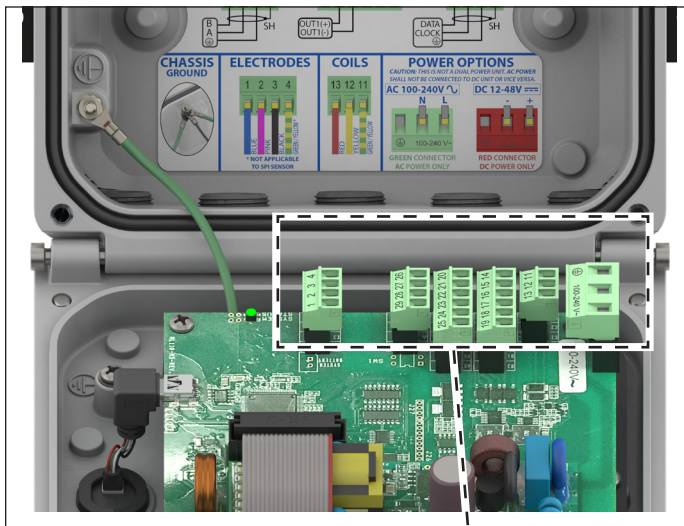

Meter mount view

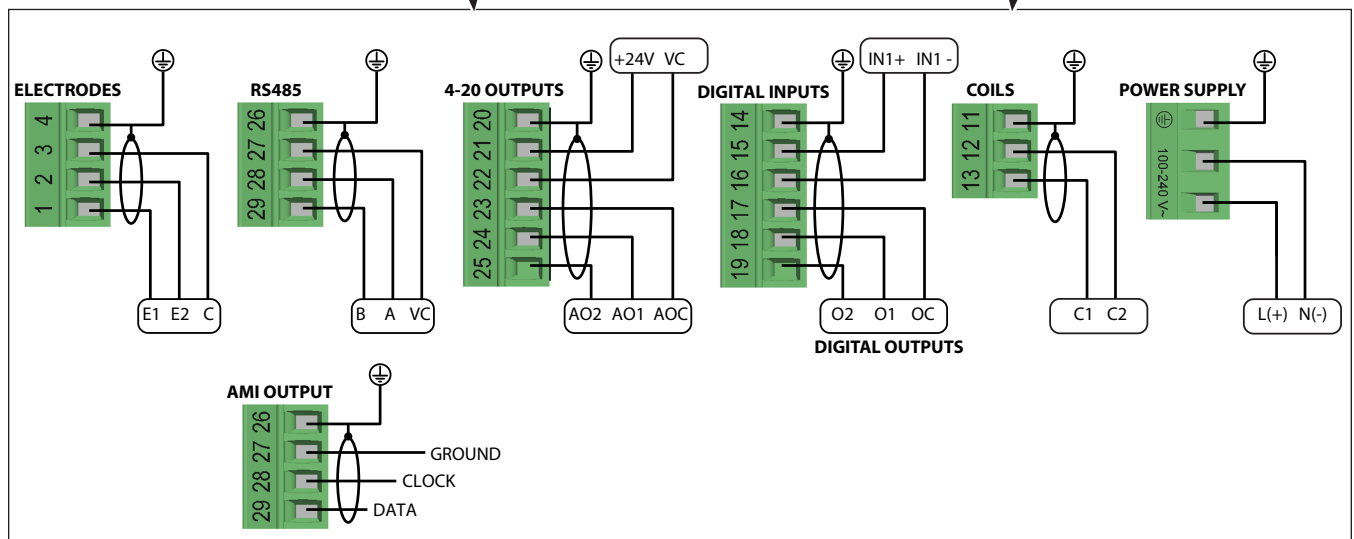
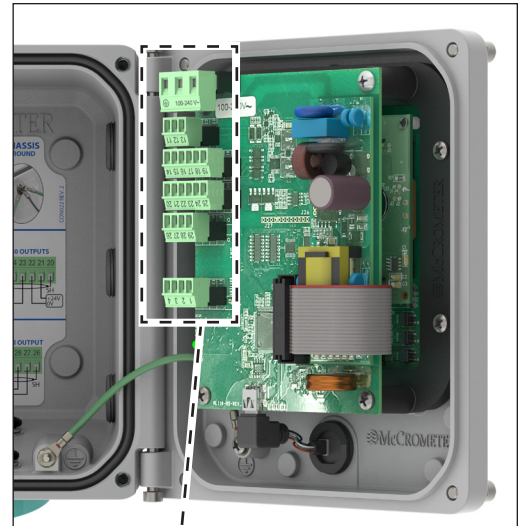

Figure 11. Terminal Block Diagram

3.2 Wiring Diagrams



CAUTION - Always disconnect the power cord before attempting any electrical connections.

FPI Mag and Ultra Mag 4" through 48"

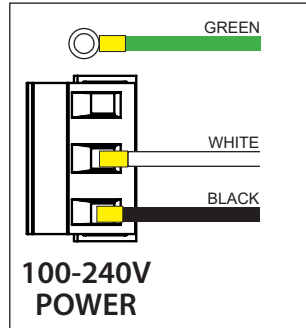
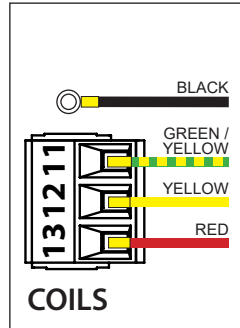
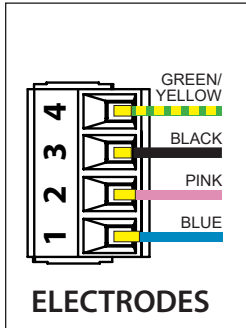

Terminal Block Assignments

Terminal	Cable	Wire Color
#1 (E1)	A	Blue
#2 (E2)	A	Pink
#3 (C)	A	Black
#4 (SH)	A	Green/Yellow
Chassis Lug	B	Black
#11 (SH)	B	Green/Yellow
#12 (C2)	B	Yellow
#13 (C1)	B	Red

Ultra Mag 2" & 3"

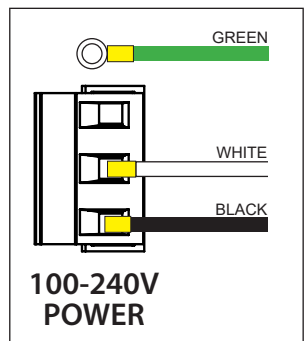
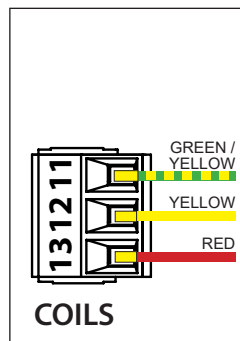
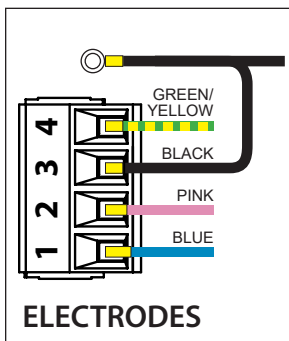

Terminal Block Assignments

Terminal	Cable	Wire Color
#1 (E1)	A	Blue
#2 (E2)	A	Pink
#3 (C)	A	Black
#4 (SH)	A	Green/Yellow
Chassis Lug	B	Black
#11 (SH)	B	Green/Yellow
#12 (C2)	B	Yellow
#13 (C1)	B	Red

SPI Mag

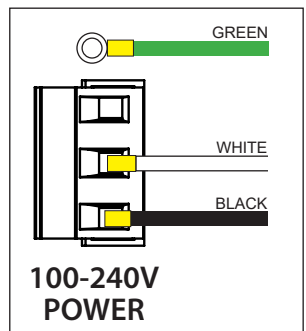
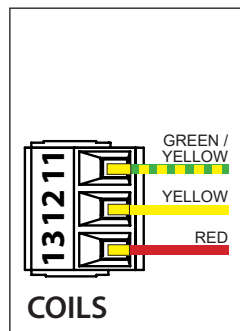
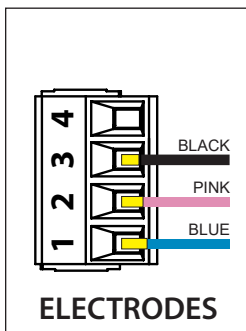

Terminal Block Assignments

Terminal	Cable	Wire Color
#1 (E1)	A	Blue
#2 (E2)	A	Pink
#3 (C)	A	Black
#11 (SH)	B	Black
#12 (C2)	B	Yellow
#13 (C1)	B	Red

All Mag sensors: Chassis Ground Connection

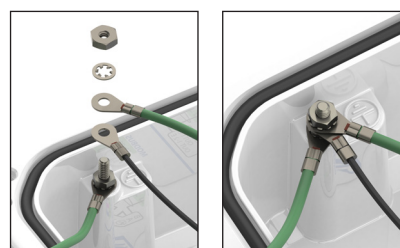

3.3 4-20mA Hook-Up

Isolated 4-20mA current loops are used to output flow data to external devices. Maximum load impedance is 1,000Ω, and the maximum voltage without load is 27VDC. The converter has the capability to detect a loss of load on this output. To disable this function set the value “mA Val. Fault” under the ALARMS menu to zero (see section 5.4). A graphical example of the usage of the current loop with external device is shown below:

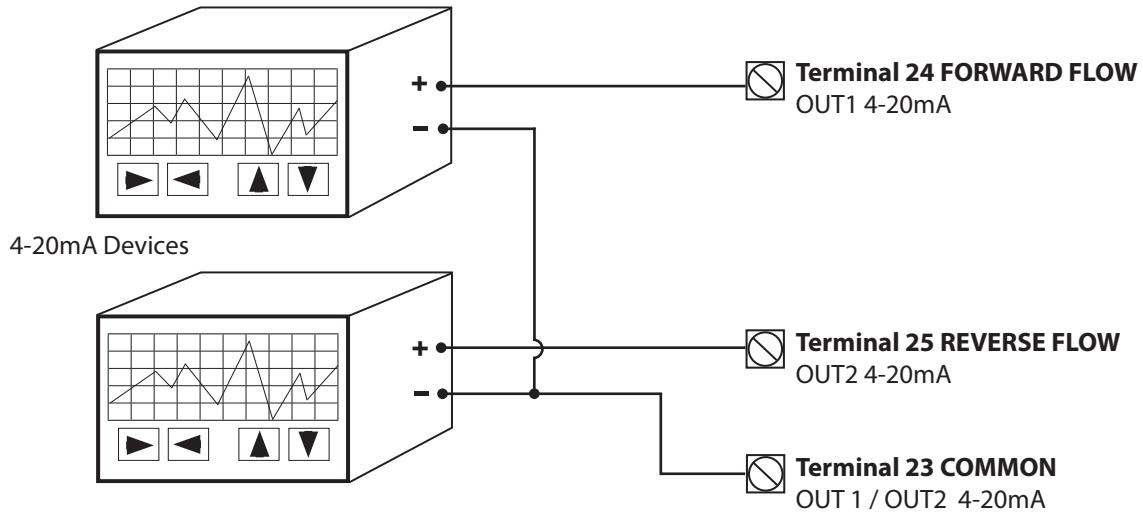

Figure 12. 4-20mA Hook-Up

If the external device requires a voltage input, a precision resistor placed across the input terminals of the external device will change the current to voltage. Calculate the required resistor using Ohm’s law ($V = I \times R$). For example, a 250Ω resistor will provide an input voltage of one to five volts with the transmitter range being set from 4mA to 20mA. An additional 4 to 20mA loop output is available.



IMPORTANT

The converter powers the 4-20mA loops. Do not use external power for the 4-20mA loop as it may cause permanent damage to the converter.

3.4 Opto-Isolated Pulse Output Hook-Up

The outputs are open collector transistor outputs used to communicate with or activate external devices.

- Opto-isolated output with collector and emitter terminals floating and freely connectable
- Maximum switching voltage: 40 VDC
- Maximum switching current: 100mA
- Maximum saturation voltage between collector and emitter 1.2V@100mA
- Maximum switching frequency (load on the collector or emitter, $R_L=470\Omega$, $V_{OUT}=24VDC$): 1250Hz
- Maximum reverse current bearable on the input during an accidental polarity reversion (VEC): 100mA
- Isolation from other secondary circuits: 500 V



IMPORTANT

Digital outputs are not isolated from each other. All digital outputs MUST use the same power source.

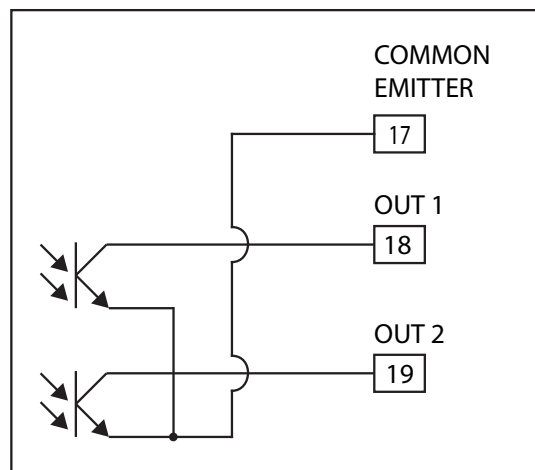

Figure 13. Opto-Isolated Pulse Output Diagram

3.5 Opto-Isolated Input

- Opto-isolated input
- 500 V isolation
- 2-40 VDC on voltage
- Input programming per input menu, will perform functions set to ON.

Input example:

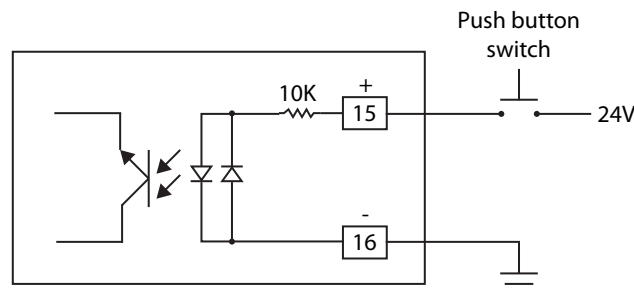

Figure 14. Opto-Isolated Input Diagram

3.6 Optional Smart Output Hook Up

The convertor comes pre-wired with an interconnection that should readily connect to most AMI transceivers. Where interconnective devices are not mechanically compatible or where non-standard wiring is encountered, the installer can opt to remove the connector from the end of the converter's interface cable and make direct connection via the wiring table shown at right.

- Signals and associated wire colors in the McCrometer SmartOutput™ interface cable are identified together in the top row of the table at right.
- Corresponding wire colors for transceivers from each compatible AMI vendor are identified in the columns under the top row.

McCrometer AMR Interface Pinout

	28 Power/Clock	29 Data	27 Ground
Badger	Red	Green	Black
Elster	Green	Red	Black
Itron	Black	Red	Green
Neptune	Black	Red	Green
Sensus	Red	Green	Black

3.7 Converter Power Wiring Diagram



WARNING!

Hazardous supply voltage can shock, burn, or cause death.

The power supply line must be equipped with external surge protection for current overload (fuse or circuit breaker with limiting capacity not greater than 10A). It must be easily accessible for the operator and clearly identified.

Power connection is made using the power terminal block on the upper right side of the terminal board.

NOTE: The terminal block unplugs from the circuit board for easy connection. Connect earth ground to the protective grounding terminal before making other connections. The power supply of a standard converter is 100-240VAC, 45-66Hz at maximum 20W. DC converter is available as an option.

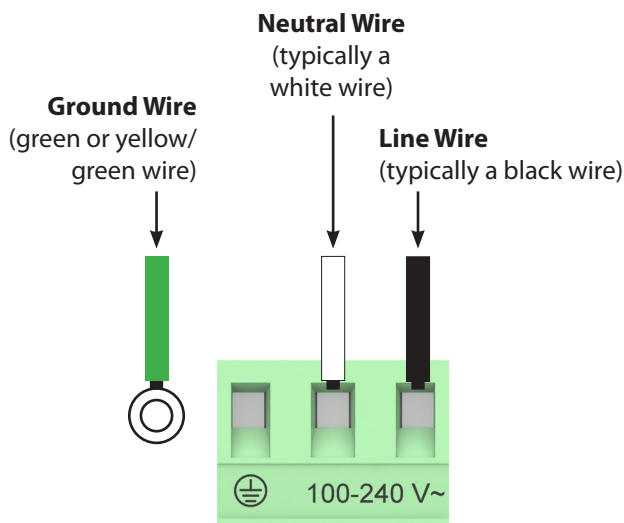

Figure 15. AC Power Supply Terminal Block

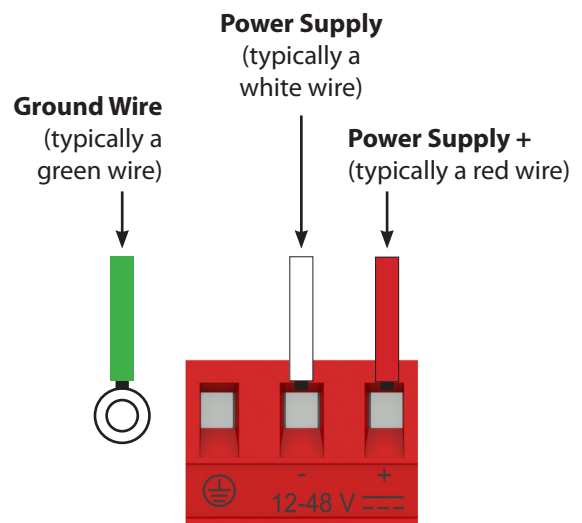

Figure 16. Optional DC Power Supply Terminal Block

4.0 **CONVERTER OPERATION**

4.1 **Starting up the Converter**

Before starting up the converter please verify the following:







- Power supply voltage must correspond to that specified on the data plate (located on the side of the converter)
- Electric connections must be wired as described in this manual
- Ground connections must be properly installed

When the converter is powered it initiates a verification cycle of the converter. During the verification cycle the converter displays an incrementing diagnostic number. When the diagnostic is complete, if an error is found, an error number will be displayed referencing the chart at the back of this manual. A text message will also be displayed on the alarm screen.

NOTE: To view alarms, press the RIGHT arrow key from the main display screen.

4.2 **Menu Navigation**

To navigate through the menus on the converter, the keys on the keypad use the following conventions:

Key	Function
 UP Key	Moves the cursor up to the previous subject on the menu Increases the numeric figure of the parameter highlighted by the cursor
 DOWN Key	Moves the cursor down to the next subject on the menu Decreases the numeric figure of the parameter highlighted by the cursor
 LEFT Key	Moves the cursor to the left on the input field Moves the cursor to the previous subject on the menu
 RIGHT Key	Moves the cursor to the right on the input field Moves the cursor to the following subject of the menu
 ENTER Key	Opens the Quick Start menu for the instrument configuration Enters the selected function Confirms the selected function
 ESC Key	Leaves the current menu Cancels the selected function under progress

4.3 Front Panel Display



Push to change to the next screen display. Each button press changes the screen and cycles through the nine displays shown below.



FLAG	DESCRIPTION
∅	Empty pipe
📁	File upload
📁	File download
▲▼	Flow rate simulation (flashing)
↔	Calibration (flashing)
⚠	Generic alarm (flashing)
🔊	General alarm only on display physical (flashing)
✖	Signal error
🔊	Excitation error
⚡	Min flow alarm
⚡	Max flow alarm
⚡	Flow rate overflow
Π1	Pulse 1 overflow
Π2	Pulse 2 overflow

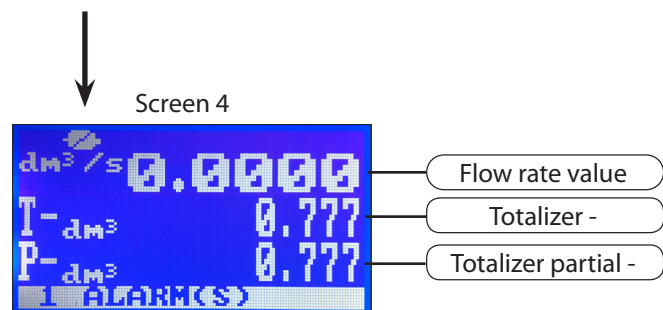
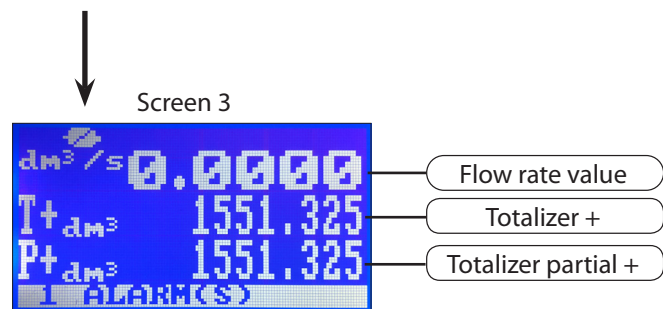
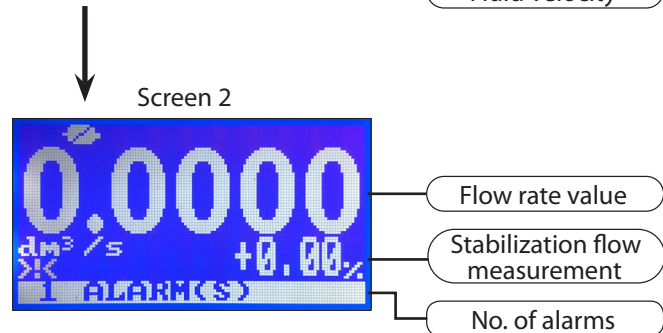
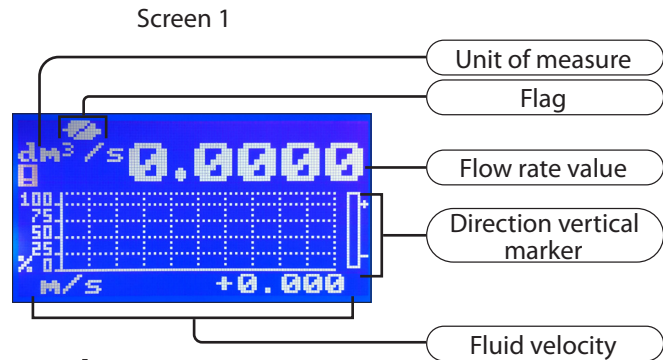

* If negatives are displayed



Screen 5



Totalizer total



Screen 6

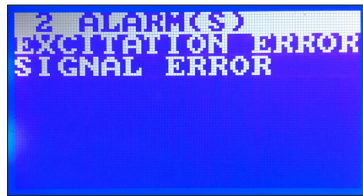

Screen 7



Totalizer partial



Screen 8



Totalizer total



Screen 9

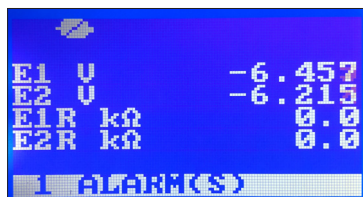

Last key press returns to screen 1



4.4 Menu Structure

The following is the menu structure for the ProComm converter. NOTE: Some menus change as options are enabled.

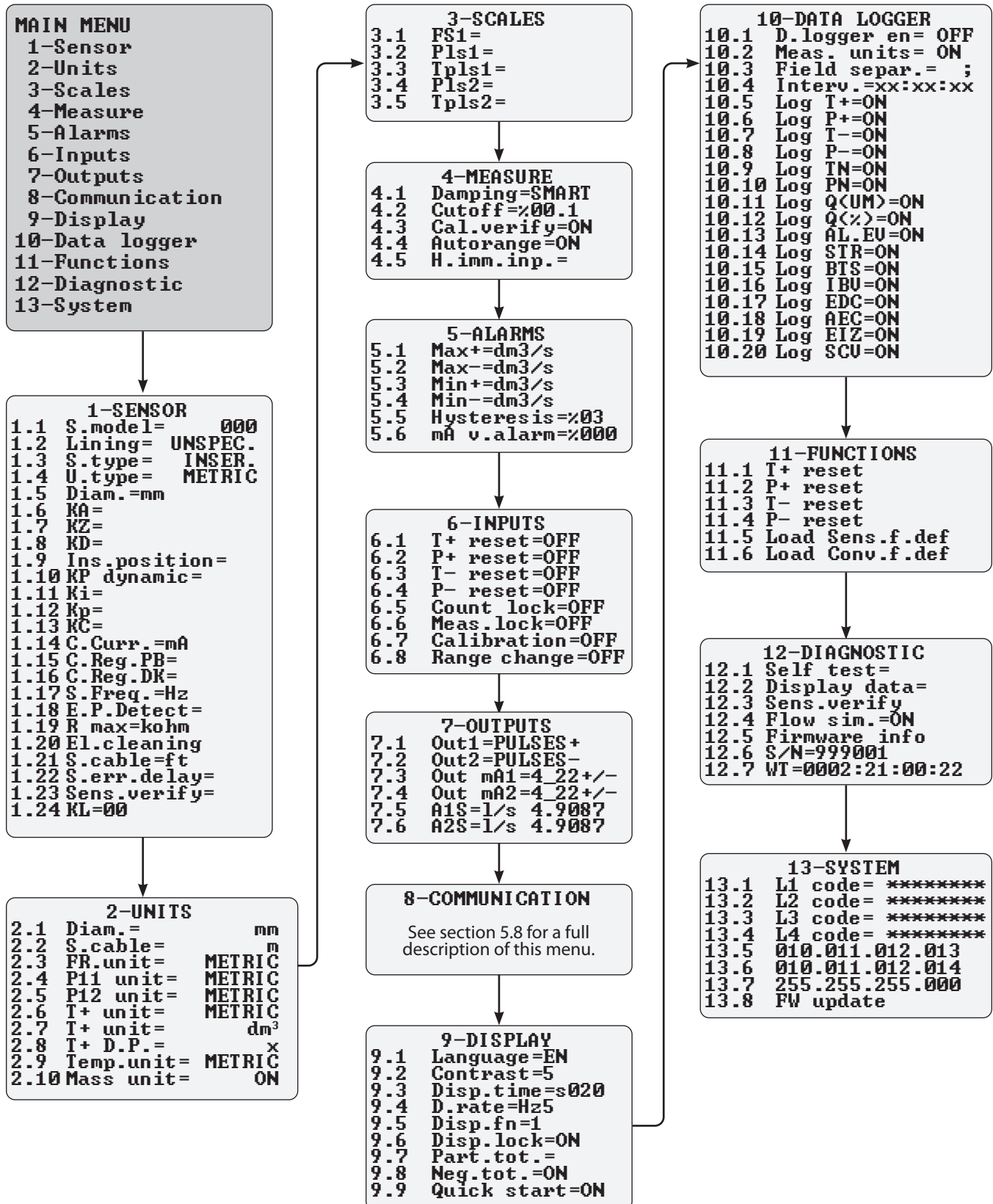

4.5 Factory Set Key Code

The converter is delivered with key code L1 = 10000000, and with the "Quick start menu" enabled. Press the Enter/Esc key. The "Quick start" menu can be enabled or disabled.



ATTENTION!

It is very important to record any customized code as it CANNOT be retrieved if it is lost!

4.6 Converter Access Code

The access for programming the instrument is regulated by four access levels logically grouped. Every level is protected by a different code.

Access levels 1-2-3-4 are freely programmable by user.

```

13-SYSTEM
13.1 L1 code= *****
13.2 L2 code= *****
13.3 L3 code= *****
13.4 L4 code= *****
13.5 010.011.012.013
13.6 011.011.012.014
13.7 255.255.255.000
13.8 FW update
    
```

The code can be set by keypad or MCP interface. Depending on the level of access, it will be in the visual display functions. These access levels determine which menu functions are available for use depending on the selected access level. See section 5.0, "MENU DESCRIPTIONS".

Factory preset access codes:

L1	10000000
L2	20000000
L3	30000000
L4	40000000
L5	57291624



WARNING!

Take careful note of the customized code, since there is no way for the user to retrieve or reset it if lost.

4.7 Changing Settings on the Quick Start Menu

The steps below demonstrate how to modify the Full Scale value from the Quick Start Menu.

1. Beginning at one of the visualization screens, press the ENTER button to go to the Quick Start Menu.

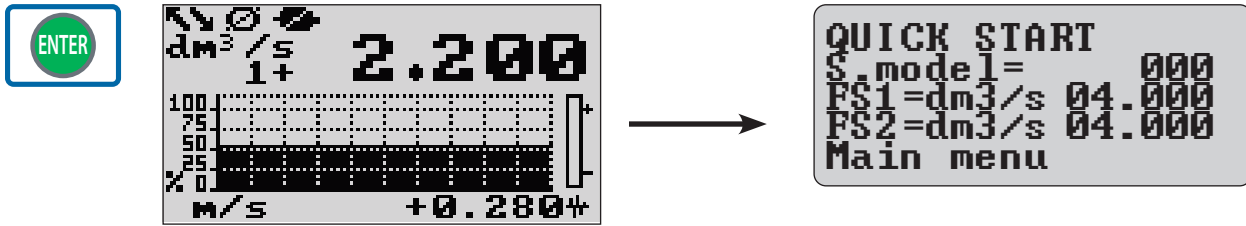

2. Press the DOWN button to select the function FS1 and press the ENTER button.

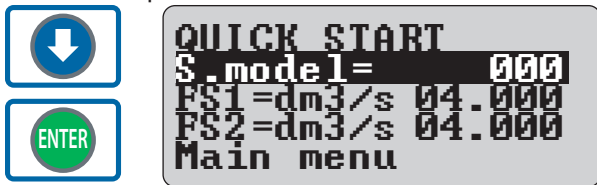

3. Press the RIGHT button to select the value.

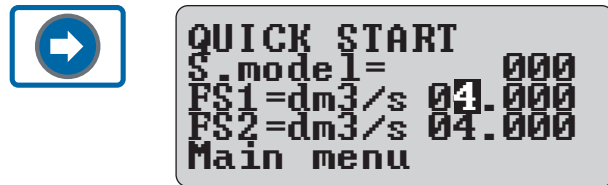

4. Press the up or down buttons to change the value.

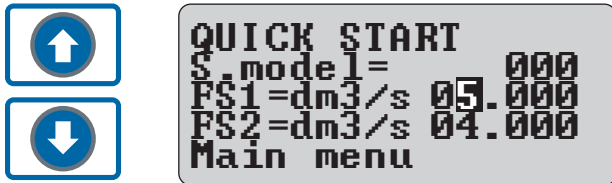

5. Press ENTER to confirm the new value.

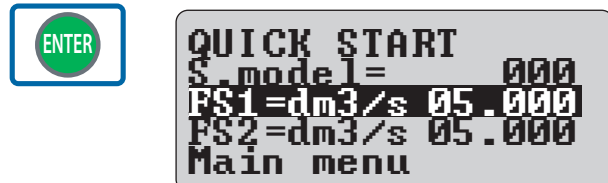

6. Press ESC to exit to the main page.

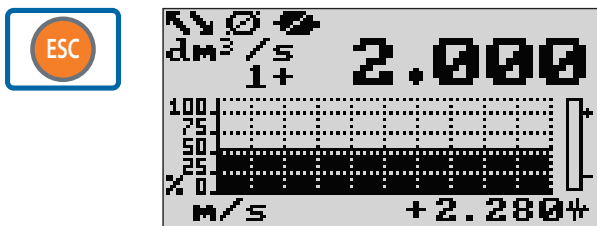

4.8 Changing Main Menu Settings

The steps below demonstrate how to modify the Full Scale value from the Main Menu.

- Beginning at one of the visualization screens, press the ENTER button.

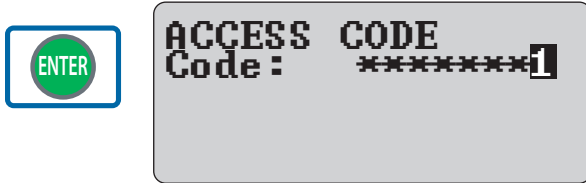

- Use the UP and DOWN buttons to enter numbers. Use the LEFT and RIGHT buttons to move to each position. When finished, press ENTER.

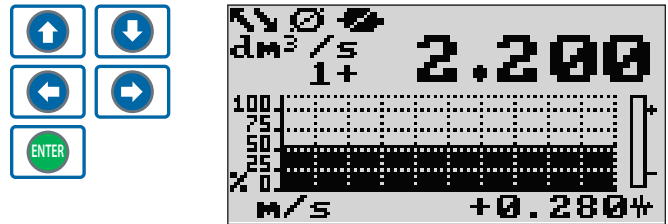

- Press the DOWN button to select Main Menu and press ENTER.

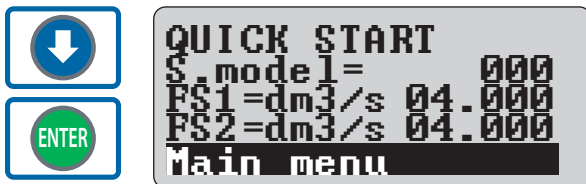

- Press the up or down buttons to select a menu and press ENTER.

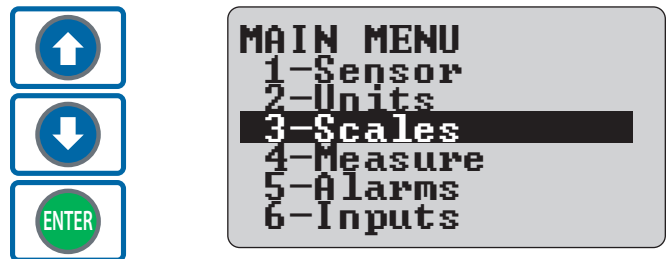

- Press the DOWN button to select the function FS1 and press the ENTER button.

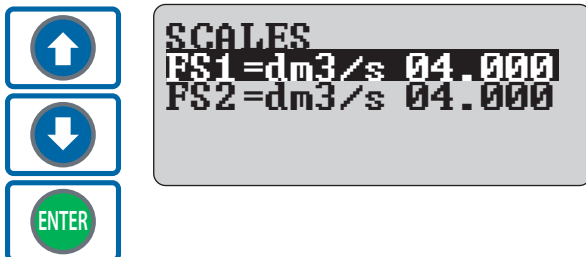

- Press the RIGHT button to select the value.

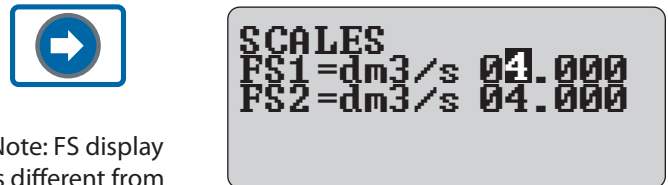

- Press the up or down buttons to change the value and then press ENTER to confirm it.

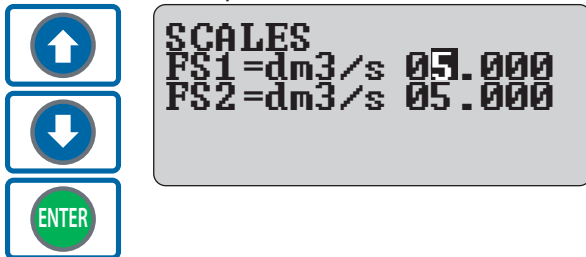

- When the change is confirmed, press ESC to return to the Main Menu.

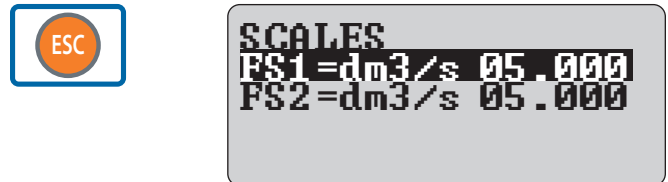

- Press ESC one more time to return to the visualization screen.

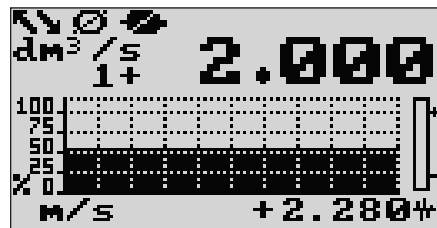
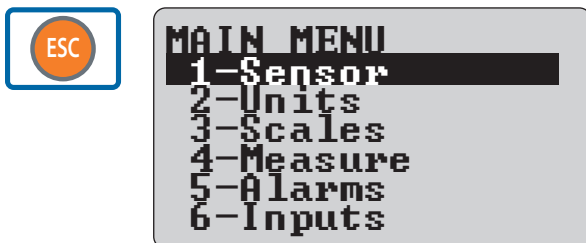

5.0 MENU DESCRIPTIONS

The main menu is selected from the Quick Start Menu by pressing the ENTER key and entering the access code (xxxxxxx). The example below shows what information each field contains.

Menu Position	Function Name	Converter Request Code	Access Level	MCP Command
1.1	Sensors model	[Ins.position=x]	AL4	[SIPOS]
This function is active with POS.1.3 on "Insertion".				
	Function Description			

Note: For ProComm users who want to use MCP software, it can be downloaded from the McCrometer Web site under the category of Installation, Operation, and Maintenance Manuals.

<https://mccrometer.hachuat.com/asset-get.download-en.jsa?id=54942158007>

5.1 Menu 1 - Sensor

Menu Position	Converter Function Code	Function Name	Function Description	Access Level	MCP Command
1.1	[S.model=x]	Sensor model		AL4	[SMODL]
1.2	[Lining=UNSPEC.]	Lining Type	Sets the flow sensor lining material type.	AL4	(LIMAT)
1.3	[S.type= FULL BORE]	Type of sensor	Sets the sensor type: Full-bore or insertion.	AL4	[STYPE]
1.4	[U.type= METRIC]	Unit type	Sets type of measurement unit: Metric or Imperial (inch).	AL4	[SUTYP]
1.5	[Diam.= mm xxx]	Diameter	Sets the nominal diameter of the sensor (0-2500). ND is written on the sensor label.	AL4	[PDIMV]
1.6	[KA= +/- xx.xxx]	KA factor	Sets the coefficient of calibration printed on the sensor label.	AL4	[CFFKA]
1.7	[KZ= +/-xxxxx]	KZ	Sets the calibration Factor. Zero adjustment	AL4	[CFFKZ]
1.8	[KD= +/-xxxxx]	KD	Sets the calibration Dynamic Factor	AL4	[CFFKD]
1.9	[Ins.position= x]	Insertion position	This function is active when selection 1.3 is set to "Insertion".	AL4	[SIPOS]
1.10	[KP dynamic= ON/OFF]	KP dynamic	This function is active when selection 1.3 is set.	AL4	[SIPOS]
1.11	[Ki= +/- xx.xxx]	Ki	This function is active when selection 1.3 is set.	AL4	[CFFKI]
1.12	[Kp dynamic= +/-xxxxx]	Kp	This function is active when selection 1.3 is set.	AL4	[SIDKP]
1.13	[KC= +/- xx.xxx]	KC	Sets the calibration factor. This function is active if the sensor model is NOT present on the sensor's table standard parameters.	AL4	[CFFKC]

Menu Position	Converter Function Code	Function Name	Function Description	Access Level	MCP Command
1.14	[C.Curr. = mA xxx.x]	Coils Ex.Current	Sets the excitation coils current. This function is active if the sensor model is NOT present on the sensor's table standard parameters.	AL4	[CEXCC]
1.15	[C.Reg.PB= xxx]	C. Reg. PB	Sets the current regulator parameter. This function is active if the sensor model is NOT present on the sensor's table standard parameters.	AL4	[CRPRB]
1.16	[C.Reg. DK = xxx]	C. Reg. DK	Sets the current regulator parameter.	AL4	[CRDER]
1.17	[S.Freq. = Hz xx]	S. Freq.	Sets the measurement sampling frequency.	AL4	[SFREQ]
1.18	[E.P.Detect= ON]	Empty Pipe Detection	Enables the empty pipe detection function.	AL3	[EPDEN]
1.19	[R max= Kohm xxxx]	Empty pipe D. Thresh.	Sets the maximum value of the electrodes' resistance.	AL4	[EPDTH]
1.20	El.cleaning	Electrode cleaning	Helps keep the electrodes clean. The allowed values are OFF, minimum, average and maximum. It is not recommended to use this function when the liquid has a conductivity less than 100µS/cm (set to OFF).	AL4	[ELCLN]
1.21	[S.cable=m xxx]	Sensor Cable	Sets the length of cable between the sensor and the converter on remote mount converter.	AL4	[SCALN]
1.22	[S.err.delay=m xxx]	Signal error delay	Sets the delay or wait time before an error generates an alarm. This function is useful to prevent zero "dropouts" of the flow signal caused by sporadic events (empty pipe, excitation error, signal error).	AL4	[SEALT]
1.23	[Sens. verify= OFF]	Sensor verify	Enables automatic sensor verification. (See BIV optional function, section 6.4.)	AL3	[ASVFE]
1.24	[KL=00]	Automatic sensor verify enable	Sets coefficient KL values	AL4	[SETKL]

5.2 Menu 2 - Units

Menu Position	Converter Function Code	Function Name	Function Description	Access Level	MCP Command
2.1	[Diam. = mm]	Diameter	Sets the sensor diameter unit of measurement: mm or inch.	AL2	[SDIUM]
2.2	[S.Cable = m]	S.cable length unit of m. type	Sets the sensor cable length for separate version. Select m or ft.	AL2	[SCAUM]
2.3	[FR unit= METRIC]	Flow rate unit of m. type	Sets the flow rate type measurement unit. Select metric or Imperial units.	AL2	[FRMUT]
2.4	[PL1 unit= METRIC]	Pulse 1 unit of m. type	This function is active with selection 7.1. It changes the measurement unit in selection 3.2. Pulse 1 type measurement unit: Metric or Imperial units.	AL2	[PL1UT]
2.5	[PL2 unit= METRIC]	Pulse 2 unit of m. type	This function is active with selection 7.2. It changes the measurement unit in selection 3.4. Pulse 2 type measurement unit: Metric or Imperial units.	AL2	[PL2UT]
2.6	[T+ unit= METRIC]	Totalizer+ unit of m. type	Sets the total direct totalizer measurement unit type: Metric or Imperial units. This function changes the measurement unit in selection 2.7.	AL2	[TTPUT]
2.7	[T+ unit= dm]	Totalizer+ unit of measure	Sets the total direct totalizer measurement unit.	AL2	[TTPUM]
2.8	[T+ D.P. = x]	Totalizer+ Decimal Point pos.	Sets the total direct totalizer decimal point position. Example:T+D.P.= 3 visualized valueT+dm ³ 0.000 T+D.P.= 2 visualized valueT+dm ³ 0.00	AL2	[TTPDP]
2.9	[Temp.unit= C/F]	Temperature unit of measure	Sets the temperature measurement unit.	AL2	[TMPUT]
2.10	[Mass units= ON/OFF]	Mass units enable	Enable or disable the selection of the mass unit of full scale.	AL2	[MSSUE]

5.3 Menu 3 - Scales

Menu Position	Converter Function Code	Function Name	Function Description	Access Level	MCP Command
3.1	[FRS1 = g/s 4908.7]	Full Rate Full Scale	The full scale is used to indicate to the meter's maximum flow rate; a volume per time is required.	AL2	[FRFS1]
<p>NOTE: The full scale should be chosen carefully as its parameters are used for several other parameters. There are four fields to fill in order to set this parameter, from left to right: 1) type of unit, 2) type of unit, 3) time unit of measure and 4) numeric value. The selection is made by positioning the cursor on the field to modify. To change the unit of measure type (metric, imperial, mass or volume) see menu 2. The following tables show the units of measure available. The converter accepts any kind of combination of units of measure satisfying both the following conditions:</p> <ul style="list-style-type: none"> • Numeric field value 99999 • $- 1/25 \text{ fsmax} \leq \text{numeric field value} \leq \text{fsmax}$. • Where fsmax is the maximum full scale value available to the sensor, equal to a 10m/s process fluid velocity. <p>The measure units are shown as appear on the display. The imperial units are differentiated by using capital and small characters.</p>					

METRIC	
cm ³	Cubic centimeter
ml	Milliliter
l	Liter
dm ³	Cubic decimeter
dal	Decalitre
hl	Hectolitre
m ³	Cubic meter
ML	Mega Liter

IMPERIAL	
in ³	Cubic inch
Gal	American gallon
IGL	Imperial gallon
ft ³	Cubic foot
bbl	Standard barrel
BBL	Oil barrel
hf ³	Hundreds of cubic feet
KGL	Kilo American gallon
IKG	Kilo Imperial gallon
kf ³	Kilo cubic feet
ttG	Tens of thousands of gallons
Aft	Acre foot
MGL	Mega gallon
IMG	Imperial mega gallon

MASS UNIT, IMPERIAL	
Oz	Ounce
Lb	Pound
Ton	Short tons

MASS UNIT, METRIC	
g	Gram
kg	Kilogram
t	Ton

NOTES FOR USING THE MCP INTERFACE

The command FRFS1 = ? and command FRS2 = ?, edited by MCP software, return a list of only the unit compatible with the nominal diameter set. If the sensor is insertion type and the diameter is zero, the only possible unit is m/s if the flow rate were chosen metric units, else f/s for the unit of measurement not metrics.

Menu Position	Converter Function Code	Function Name	Function Description	Access Level	MCP Command
3.2	[Pls1=g1000.00]	Output Pulse 1	Pls1 is active with POS.7.1. This enables and sets the pulse value on channel 1. This function allows the user to set a signal (a pulse) to be given from the converter when a defined amount of liquid has passed through the sensor.	AL2	[OP1PV]
<p>To set the parameter, complete the two fields, from left to right: 1)measure unit, 2) numeric value. To change the unit type (metric, Imperial, mass or volume), see POS.2.4-2.5 and POS.2.19-2.20. The value of Pls1 depends on nominal diameter POS.1.4. Only those units described (POS.3.1-3.2) above are available for selection.</p> <p>NOTE: Since the converter can not detect which two problems may occur, first, if the pulse is too long, the coils may burn out, and second, if the pulse is too short, the counter may not be able to function due to the possibility of causing damage of the output.</p>					
3.3	[Tpls1=ms0050.0]	Output Pulse 1 time	Tpls1 is active with POS.7.1 is enabled. This sets the duration of the pulse generated on channel, with the liquid volume to generate the pulse value (POS.3.3-3.5) set by the user.	AL2	[OP1PT]
<p>The user must set the corresponding duration of the pulse for output. This value is expressed in milliseconds and has to be between 0.4 and 9999.99.</p>					
3.4	[Pls2=g1000.00]	Output Pulse 2	See menu 3.2, Output Pulse 1	AL2	[OP2PV]
3.5	[Tpls2=ms0050.0]	Output Pulse 2 Time	See menu 3.3, Output Pulse 1 Time	AL2	[OP2PT]

5.4 Menu 4 - Measure

Menu Position	Converter Function Code	Function Name	Function Description	Access Level	MCP Command
4.1	[Damping=SMART]	Damping	This setting adjusts how quickly the converter responds to momentary changes in flow. Settings range from Damping=OFF (immediate response but noisy signal) to 1000s (slow response to changes in flow but quiet signal).	AL3	[MFDMP]

The following diagrams show the instrument's response to changes in flow rate from 0 to 100% using the different settings of the damping function.

The SMART setting is an adaptive filter that adapts automatically to changes in process fluid flow, making the meter very responsive to fast changes in flow and at the same time extremely precise and stable for slow variations.

NOTE: If the rechargeable battery is active, the damping can be set only to SMART.

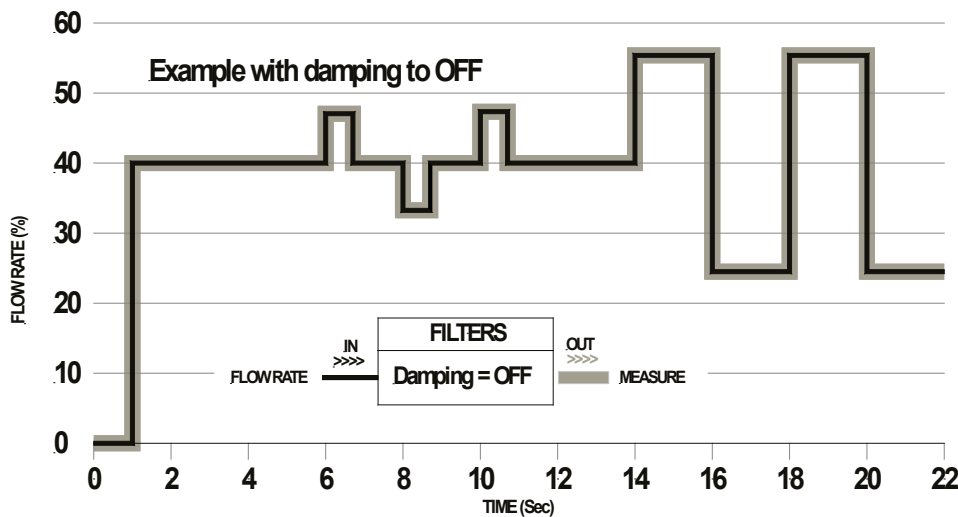

Damping function OFF. The meter follows the trend of fast changes in flow.

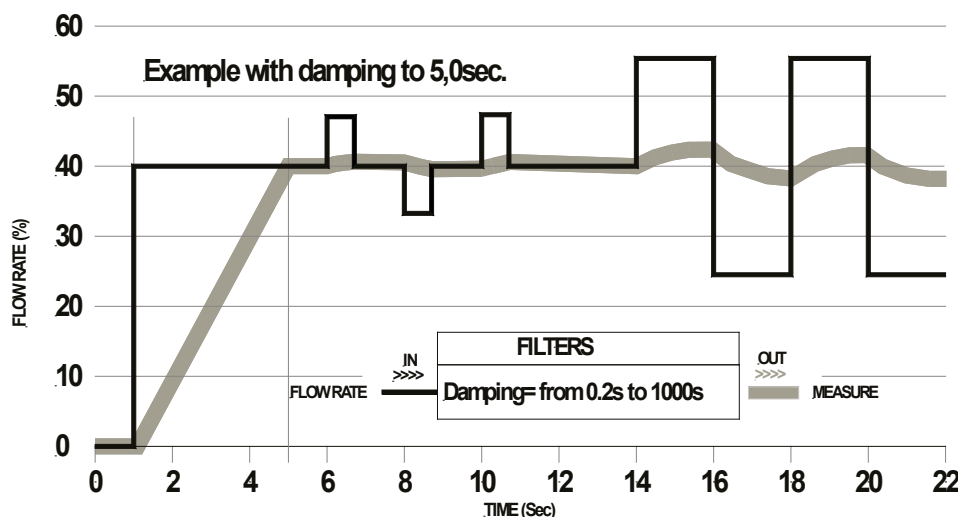

Example with damping mode based on time (from 0.2s to 1000s).

The measure is averaged over a number of samples determined by the value assigned to the dampening function. When the damping parameter is expressed in seconds, the filter works by damping the measurement noise and shows a sudden change of flow rate. Increasing the damping parameter increases measurement stability.

Menu Position	Converter Function Code	Function Name	Function Description	Access Level	MCP Command
4.2	[Cutoff=%00.1]	Cut-off threshold	Sets the low flow cutoff threshold. This function is useful to avoid erroneous totalizer increases at zero flow due to electrical noise.	AL3	[MFCUT]
	Note: The allowed range for this function is 0-25% of full scale set. For most applications a value of 2% is recommended.				
4.3	[Cal.verify=ON]	Calibration verify	This function enables automatic verification of the board's coefficients.	AL3	[ACAVE]
	Note: As the converter performs continuously a large number of tests, we recommend to use this function only in presence of wide range of temperature.				
4.4	[Autorange=ON]	Automatic scale change enable	Enables the automatic change of scale.	AL3	[ARNGE]
	<p>The meter may have two different working ranges in order to suit to the variable process conditions. In order to get the best results out of this function, it is important range N.2 (Fs2) (if enabled) is bigger than N.1 (Fs1) of the full scale 1. The meter will automatically switch to scale 2. When the flow rate decreases again reaching a value on scale 2 equal to the 90% of full scale N.1, the active scale is switched to 1 again. Allowed values for this parameter are ON/OFF.</p> <p>Note: When the autorange is enabled, it is not allowed to use the manual range change.</p> <p>This function does NOT increase measurement accuracy. Its aim is to increase the resolution of 4/20 mA when the meter works at very low flow rates. A typical case would be the flow rate of water distribution with daytime flow is much higher than the night flow.</p>				
4.5	[H.imm.inp.=]			AL3	

MCP ONLY FUNCTIONS

Menu Position	Converter Function Code	Function Name	Function Description	Access Level	MCP Command
	[MCP ONLY]	Measure Filter Cut-off Threshold 2	Sets the low flow cutoff threshold. This is similar to the function in 4.2. The value of this function is NOT visible on the display but only with MCP command.	AL3	[MFCT2]

5.5 Menu 5 - Alarms

Menu Position	Converter Function Code	Function Name	Function Description	Access Level	MCP Command
5.1	[Max+=dm3/s]	Maximum flow rate threshold direct	Sets the maximum value alarm for direct flow rate setting. When the flow rate value exceeds such the threshold, an alarm message is generated. The value of this parameter is expressed as percentage of the full scale value and may be set from 0 to 125%. Setting this parameter to zero corresponds with disabling the alarm generation.	AL3	[FRAXP]
5.2	[Max-=dm3/s]	Maximum flow rate threshold negative	Sets the maximum value alarm set for reverse flow rate setting. When the flow rate value exceeds such a threshold, an alarm message is generated. The value of this parameter is expressed as percentage of the full scale value and may be set from 0 to 125%. Setting this parameter to zero corresponds with disabling the alarm generation.	AL3	[FRAXN]
5.3	[Min+=dm3/s]	Minimum flow rate threshold positive	Sets the minimum value alarm set for reverse flow rate set. When the flow rate value falls below such a threshold, then an alarm message is generated. The value of this parameter is expressed as percentage of the full scale value and may be set from 0 to 125%. Setting this parameter to zero corresponds with disabling the alarm generation.	AL3	[FRANP]
5.4	[Min-=dm3/s]	Minimum flow rate threshold negative	Sets the minimum value alarm set for reverse flow rate set. When the flow rate value falls below such a threshold, then an alarm message is generated. The value of this parameter is expressed as percentage of the full scale value and may be set from 0 to 125%. Setting this parameter to zero corresponds with disabling the alarm generation.	AL3	[FRANN]

Menu Position	Converter Function Code	Function Name	Function Description	Access Level	MCP Command
5.5	[Hysteresis=%03]	Hysteresis	Sets the hysteresis threshold set for the minimum and maximum flow rate alarms. The value of this parameter is expressed as percentage of the full scale value and may be set from 0 to 25%.	AL3	[ATHYS]
5.6	[mA v.alarm=%000]	Current output value in case of failure	The output current signal can be specified by the user in case of failure of either, empty pipe, coils interrupted, or ADC error.	AL3	[OCACV]
<p>The signal current is set as a percentage (0 to 125%) of the 0/4-20mA current. 125% corresponds to 24mA and does not depend on the selected range (0-20/4-20mA). The NAMUR NE43 recommendation suggests an alarms signalling value for the current output lower than 3.6mA (<18%) or greater than 21mA (>105%). It would be preferable to set the function to 10%. This would bring the current to 2mA in the event of the aforementioned faults and allow the diagnostics shown below:</p> <ul style="list-style-type: none"> • Current < 2mA - 5%: line interrupted, power supply failure or faulty converter • 2mA - 5% * current * 2mA + 5%: hardware alarm; • 4mA * current * 20mA: normal working range; • 20mA < current * 22mA: out of range, measure above 100% out of range 					

5.6 Menu 6 - Inputs

Menu Position	Converter Function Code	Function Name	Function Description	Access Level	MCP Command
6.1	[T+ reset=OFF]	[T+ reset=OFF]	When this function is enabled, the related totalizer + may be reset through the on/off input.	AL3	[VTTPE]
6.2	[P+ reset=OFF]	[P+ reset=OFF]	When this function is enabled, the related totalizer + may be reset through the on/off input.	AL3	[VTPPE]
6.3	[T- reset=OFF]	[T- reset=OFF]	When this function is enabled, the related totalizer - may be reset through the on/off input.	AL3	[VTPNE]
6.4	[P- reset=OFF]	[P- reset=OFF]	When this function is enabled, the related totalizer - may be reset through the on/off input.	AL3	[VTTNE]
6.5	[Count lock=OFF]	[Count lock=OFF]	Enables the totalizers counting lock. When this function is active, when applying a voltage to the on/off input terminals, the system stops the totalizers no matter which is the flow rate.	AL3	[TCLIE]

Menu Position	Converter Function Code	Function Name	Function Description	Access Level	MCP Command
6.6	[Meas . lock=OFF]	[Meas.lock=OFF]	When this function is active (ON), applying a voltage to the on input terminals, the measurement is stopped and the meter will display zero flow.	AL3	[MSLIE]
6.7	[Calibration=OFF]	[Calibration=OFF]	When this function is active, applying a voltage to the on/off input terminals, the meter performs an autozero calibration cycle.	AL3	[CALIE]
<p>Note: If the voltage pulse is less than 1 second, the meter performs a calibration cycle to compensate for possible thermal drifts. If the voltage pulse is more 1 second, the meter performs a zero calibration measure. To perform the calibration, it is absolutely necessary for the pipe to be full of liquid and that the liquid is perfectly still. Even very small movement of the liquid may affect the result of the calibration and consequently the accuracy of the system.</p>					
6.8	[Range change =OFF]	[Range change=OFF]	Enables the range change external command. When this function is enabled, applying a voltage to the on/off input terminals, the meter switches to the second measuring range (Fs2).	AL3	[SRCIE]
<p>Note: The autorange does not allow manually changing the range. See POS. 4.4.</p>					

5.7 Menu 7 - Outputs

Menu Position	Converter Function Code	Function Name	Function Description	Access Level	MCP Command
7.1	[Out1=PULSES+]	Output 1 function selection	Sets the selection for Output 1. The functions are listed in the table below.	AL3	[OUT1F]
7.2	[Out2=PULSES-]	Output 2 function selection	Sets the selection for Output 2. The functions are listed in the table below.	AL3	[OUT2F]
FUNCTIONS FOR OUTPUTS 1 AND 2 OFF: DISABLE MAX AL. +: MAX DIRECT FLOW RATE OUTPUT (ENERGIZED = AL. OFF) MIN AL. +: MIN DIRECT FLOW RATE OUTPUT (ENERGIZED = AL. OFF) MAX/MIN+: POSITIVE FLOW RATE OUTPUT (ENERGIZED = AL. OFF) MAX AL.-: MAX INVERSE FLOW RATE OUTPUT (ENERGIZED = AL. OFF) MIN AL.-: MIN INVERSE FLOW RATE OUTPUT (ENERGIZED = AL. OFF) MAX/MIN-: MAX/MIN INVERSE FLOW RATE OUTPUT (ENERGIZED = AL. OFF) MAX/MIN+/-: MAX/MIN DIRECT FLOW RATE OUTPUT (ENERGIZED = AL. OFF) P.EMPTY: EMPTY PIPE ALARM OUTPUT (ENERGIZED = AL. OFF) HARDW.AL.: SUM OF ALL ALARMS "energized interrupted " AND "error input signal " OVERFLOW: OUT OF RANGE ALARM OUTPUT (ENERGIZED = FLOWRATE OK) ALL ALARMS: SUM OF ALL ALARMS POSSIBLE EXT.COMM.: OUTPUT MAY TAKE A STATE FROM AN EXTERNAL CONTROL (MCP, MODBUS, etc.) FLOW RATE SIGN.: FLOW DIRECTION (ENERGIZED WHEN FLOW IS NEGATIVE) SCALE: INDICATION SCALE FREQ.+: FREQUENCY POSITIVE FLOWRATE FREQ.-: FREQUENCY NEGATIVE FLOWRATE FREQ.+/-: FREQUENCY POSITIVE/NEGATIVE FLOWRATE PULSES+: PULSE POSITIVE VOLUME PULSES-: PULSE NEGATIVE VOLUME PULSES+/-: PULSE NEGATIVE/POSITIVE VOLUME					
7.3	[Out mA1=4_22+/-]	Current output option and range	Sets the current Output 1.	AL3	[OUT1F]

Menu Position	Converter Function Code	Function Name	Function Description	Access Level	MCP Command
7.4	[Out mA2=4_22+/-]	Current output option and range	This function sets the current output 2.	AL3	[OUT2F]

This function is optional and will not appear unless the option has been requested. There are three fields to modify for this function:

- Scale zero: 4 or 0mA
- Full scale: 20 or 22mA
- Field: + = positive, - = negative, blank = both, -0+ = central zero scale

The values corresponding to the scale points are shown in the following chart:

CURRENT VALUES IN mA CORRESPOND TO THE % FULL SCALE VALUE					
POSSIBLE FIELD	REVERSE FLOW VALUE		ZERO	DIRECT FLOW VALUE	
	≤-110%	-100%	0%	+100%	≥+110%
Out.mA = 0 ÷ 20 +	0	0	0	20	20
Out.mA = 0 ÷ 22 +	0	0	0	20	22
Out.mA = 4 ÷ 20 +	4	4	4	20	20
*Out.mA = 4 ÷ 22 +	4	4	4	20	21.6
Out.mA = 0 ÷ 20 -	20	20	0	0	0
Out.mA = 0 ÷ 22 -	22	20	0	0	0
Out.mA = 4 ÷ 20 -	20	20	4	4	4
Out.mA = 4 ÷ 22 -	21.6	20	4	4	4
Out.mA = 0 ÷ 20	20	20	0	20	20
Out.mA = 0 ÷ 22	22	20	0	20	22
Out.mA = 4 ÷ 20	20	20	4	20	20
Out.mA = 4 ÷ 22	21.6	20	4	20	21.6
Out.mA = 0 ÷ 20 -0+	0	0	10	20	20
Out.mA = 0 ÷ 22 -0+	0	1	11	21	22
**Out.mA = 4 ÷ 20 -0+	4	4	12	20	20
Out.mA = 4 ÷ 22 -0+	2	4	12	20	22

* Example 1: out 4-22 +

** Example 2: out 4-20 -0+

In hardware alarm conditions "HARDW AL." (interrupted coils, empty pipe, measure error) the current value is programmed by the function "mA v.fault" (pos. 5.6) and it is expressed as percentage of a fixed current range, where: 0% = 0mA and 110% = 22mA.

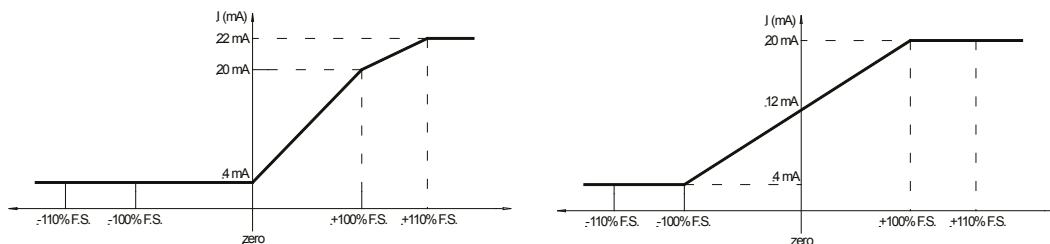

Menu Position	Converter Function Code	Function Name	Function Description	Access Level	MCP Command
7.5	[A1S=dm3/s 4.9087]	Analog Output1 full scale	Sets the full scale value for analog output 1 independently of the main scale of the instrument	AL3	[AO1FS]
7.6	[A2S=dm3/s 4.9087]	Analog Output2 full scale	Sets the full scale value for analog output 1 independently of the main scale of the instrument	AL3	[AO2FS]

5.8 Menu 8 - Communication

The Communication menu will populate with commands that are specific to the output mode or protocol that the converter is configured to. The menus shown below are for Hart, MODBUS, and AMR.

HART

Menu Position	Converter Function Code	Function Name	Function Description	Access Level	MCP Command
8.1	[HART pr.=XXXXXX]	Hart Preamble	Number of preamble (Hart function)	AL3	[HARTP]
8.2	[HART o.c.=XXXXXX]	Hart Bus Output Control	ON=Hart Control of Output 1 4-20mA OFF=Normal Output 1 4-20mA	AL3	[HRTOC]
8.3	[HART find d=XXXXXX]	Hart Find Device Function	ON=Armed Will respond to Command #73 OFF=Disabled	AL3	[HRTFD]
8.4	[HART w.p.=XXXXXX]	Hart Write Protect	ON=Allows Write Protect through Command #128 OFF=Disabled	AL3	[HRTWP]
8.5	[Dev. Addr=XXXXXX]	Device Address		AL3	[DVADD]

MODBUS

Menu Position	Converter Function Code	Function Name	Function Description	Access Level	MCP Command
8.1	[Dev. Addr=XXXXXX]	Device Address		AL3	[DVADD]
8.2	[Speed=bps9600]	Speed	Baud Rate	AL3	[MDBSP]
8.3	Parity=no	Parity		AL3	[MDBPA]
8.4	Delay=ms00	Delay		AL3	[MDPDL]
8.5	[C.timeout=2]	Time Out		AL3	[MDBCT]

AMR

Menu Position	Converter Function Code	Function Name	Function Description	Access Level	MCP Command
8.1	T.RD.p.t=MIM087 (Sensus)			AL3	[TRDPT]
8.2	MIM086 (Itron 6)				
8.3	MIM085 (Itron 9)				

5.9 Menu 9 - Display

Menu Position	Converter Function Code	Function Name	Function Description	Access Level	MCP Command
9.1	[Language =EN]	Language for all msn	Sets the language selection. There are 2 languages available: EN = English, IT = Italian.	AL1	[LLANG]
9.2	[Contrast =5]	Display Contrast	Sets the display contrast. The contrast can change according to the room temperature. The allowed range is from 0 to 9.	AL1	[DCNTR]
9.3	[Disp.time =s020]	Keyboard Timeout Time	Sets display/keyboard inactivity. The set values are from 020 to 255 second.	AL1	[KBTMT]
9.4	[D.rate =Hz5]	Display Refresh Frequency	Sets the frequency of the display data update. This parameter effects only the display layout and not the response time of the meter itself. The possible choices are: 1/2/5/10 Hz.	AL1	[DISRF]
9.5	[Disp.fn =1]	Display function number	Sets the display of the page making it visible when you start the display. Each display page is associated with a number that corresponds to Pos 9.5.	AL2	[DISFN]
9.6	[Disp.lock =ON]	Display function lock	Locks display page sliding selected by Pos 9.5.	AL2	[DLOKE]
9.7	[Part.tot. =]	Partial totalizer	This function enables the display of partial totalizer in visualization pages	AL2	[PTOTE]
9.8	[Neg.tot. =ON]	Negative totalizer	This function enables the display of negative totalizer in visualization pages	AL2	[NEGTE]
9.9	[Quick start =ON]	Quick start menu	This function enables the display of date and time in visualization pages	AL2	[QSTME]

5.10 Menu 10 - Data Logger

Menu Position	Converter Function Code	Function Name	Function Description	Access Level	MCP Command
10.1	[D.logger en =OFF]	Data logger enable	Enables the data logger.	AL3	[DLOGE]

Menu Position	Converter Function Code	Function Name	Function Description	Access Level	MCP Command
The following functions are activated by [D.logger en= ON]					
10.2	[Meas. units= ON]	Unit of Measure	Measure unit recording enable	AL3	[DLUME]
10.3	[Field separ.= ;]	Field separator character	This function will set the separator character between data logger data.	AL3	[DLFSC]
10.4	[Interv.=xx:xx:xx]	Sample Interval	Sampling interval. This function scans the log frequency. [Interv.= Hours : Minutes: Seconds]	AL3	[DLGSI]
10.5	[Log T+=ON]	Totalizer Total positive	Enable logging of total direct totalizer.	AL3	[DTTPE]
10.6	[Log P+=ON]	Totalizer Partial positive	Enable logging of partial direct totalizer.	AL3	[DTPPE]
10.7	[Log T-=ON]	Totalizer Total Negative	Enable logging of total reverse totalizer	AL3	[DTTNE]
10.8	[Log P-=ON]	Totalizer Partial Negative	Enable logging of partial reverse totalizer	AL3	[DTPNE]
10.9	[Log TN=ON]	Totalizer Total Net	Enable logging of total net totalizer	AL3	[DLTNE]
10.10	[Log PN=ON]	Totalizer Partial Net	Enable logging of partial net totalizer	AL3	[DLPNE]
10.11	[Log Q<UM>=ON]	Log Flow rate in measure unit	Enable logging of flow rate in measure unit	AL3	[DFTUE]
10.12	[Log Q<%>=ON]	Log Flow rate in percentage	Enable recording of the flow rate as a percentage of full scale value set.	AL3	[DFPCE]
10.13	[Log AL.EU=ON]	Alarm events	Enable logging of alarm events	AL3	[DALEE]
10.14	[Log STR=ON]	Sensor test result	Enable logging of sensor test results	AL6	[DSTRE]
10.15	[Log BTS=ON]	Board temperatures	Enable logging of board temperature	AL6	[DBTSE]
10.16	[Log IBU=ON]	Internal board voltages	Enable logging of internal board voltage	AL6	[DIBVE]
10.17	[Log EDC=ON]	Electrodes DC voltages	Enable logging of electrodes DC voltage	AL6	[DEDVE]
10.18	[Log AEC=ON]	Electrodes AC voltages	Enable logging of electrodes AC voltage	AL6	[DEAVE]
10.19	[Log EIZ=ON]	Electrodes source impedance	Enable logging of electrodes impedance	AL6	[DESIE]
10.20	[Log SCU=ON]	Sensor coils values	Enable logging of sensor coils value	AL6	[DSCVE]

DATA LOGGER: ONLY MCP FUNCTIONS

Menu Position	Converter Function Code	Function Name	Function Description	Access Level	MCP Command
	[MCP ONLY]	LoG All Information Enable	Log all events information. This function save in the event file all MCP commands.	AL6	[LGAIE]

USING DATA LOGGER BY MCP INTERFACE

Data are stored on micro SD card; the organization is based on "tree-structure": the system create a daily folder where it save events and data logger . The data can be downloaded for MCP interface. (See example at right.)

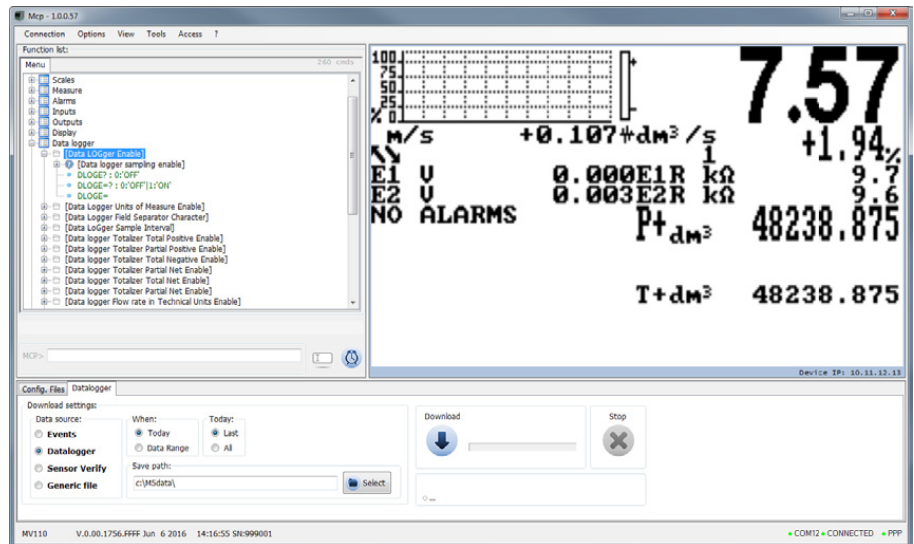

Click tab-control data logger to view files.

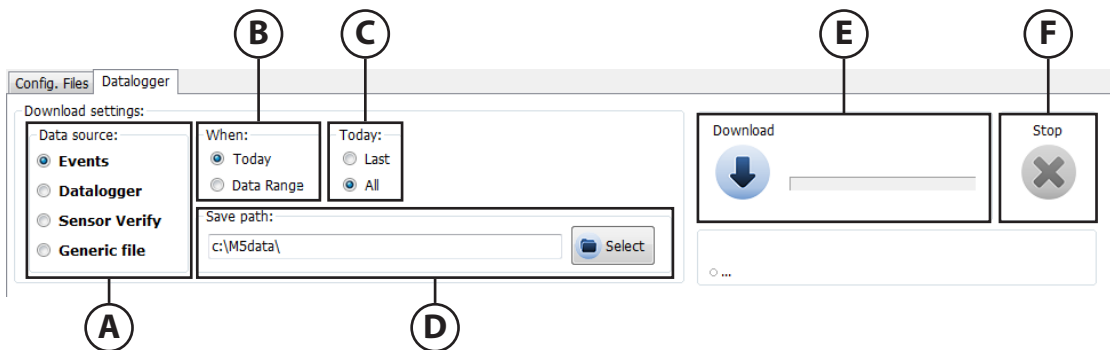

The sampling data backup depends on the value set by the POS function 10.4.

- A=Data source**
 - Events:** Save the file system events (Example F-RAM hardware data [WORKING AREA] [SUCCESSFULLY LOADED])
 - Data logger:** Save files of data logger function enabled.
 - Sensor Verify:** Data logged by BIV function
 - Generic file:**
- B=When**
 - Today:** It indicates the download file for the current day
 - Data range:** This option allows you to select the date range for download.

- C=Today**
 - Last:** This option allows to download the latest files, recorded after the last download
 - All:** this option allows the download of all the current day of the file
- D=Save path:** This option allows you to save files to the folder on your PC
- E=Download:** Button to start the download process
- F=Stop:** Button to stop the download process

5.11 Menu 11 - Functions

Menu Position	Converter Function Code	Function Name	Function Description	Access Level	MCP Command
11.1	[T+ reset]	Totalizer Total Positive reset	Resets the total direct totalizer for direct flow rate (+)	AL3	[VTTPR]
11.2	[P+ reset]	Totalizer Par. Positive reset	Resets the total partial totalizer for direct flow rate (+)	AL3	[VTPPR]
11.3	[T- reset]	Totalizer Total Neg. reset	Resets the total reverse totalizer for direct flow rate (-)	AL3	[VTTNR]
11.4	[P- reset]	Totalizer Partial Neg. reset	Resets the partial reverse totalizer for direct flow rate (-)	AL2	[VTPNR]
11.5	[Load Sens.f.def]	Load factory default sensor	Resets the parameters of the sensor factory default	AL3	[LFDSD]
11.6	[Load Conv.f.def]	Load factory default converter	Resets the parameters of the converter factory default.	AL3	[LFD CD]

FUNCTION: ONLY MCP FUNCTIONS

Menu Position	Converter Function Code	Function Name	Function Description	Access Level	MCP Command
	[MCP ONLY]		Saves sensor reference data	AL4	[SRFDS]

5.12 Menu 12 - Diagnostic

Menu Position	Converter Function Code	Function Name	Function Description	Access Level	MCP Command
12.1	[Self test=]	Self Test Diagnostic	Meter auto-test function. This function stops the normal functions of the meter and performs a complete test cycle on the input circuits measurement and on the excitation generator.	AL3	[ATSIC]
<p>To activate, after selecting the function, press Enter at the question: "CONFIRM EXEC.?" Press ESCAPE to start the auto-test or any other key to stop the operation. At the end of operation, the converter will revert to one of the initial visualization pages. This function is automatically performed when switching on the device. This function restart the converter.</p>					
12.2	[Display test=]	Test Display	This function performs a physical test graphic display. During this operation, four sequences are displayed to test that the device functions properly.	AL3	NO MCP COMMAND
12.3	[Sens.verify]	Sensor Verify	This function performs a manual sensor verification (if BIV is active)	AL3	[SVERC]

Menu Position	Converter Function Code	Function Name	Function Description	Access Level	MCP Command
12.4	[Flow sim.=ON]	Flow Rate Simulation	Enables flow rate simulation. With this function, it is possible to generate an internal signal that simulates the flow rate and allows for testing the outputs and all the connected instruments.	AL3	[MSIEN]
After enabling it, a ▲▼ appears in the top left of the screen and the flow rate simulation can be: <ul style="list-style-type: none"> • <u>Set</u>: Press Enter on one of visualization pages. This sets the required % flow rate (Fl. rate=%). Pressing the Enter key confirms the value. • <u>Finished</u>: Press Enter on one of the visualization pages and then make a long press on the same key. 					
12.5	[Firmware info]	Firmware Info	Shows the firmware info version/revision (read only)	AL0	[DMVLS]
12.6	[S/N=999001]	Board Serial Number	Shows the board serial number (read only)	AL0	[DMVLS]
12.7	[WT=0002:21:00:22]	Working Time	Shows the instrument's total working time (read only)	AL0	[TWKTM]

5.13 Menu 13 - System

Menu Position	Converter Function Code	Function Name	Function Description	Access Level	MCP Command
13.1	[L1 code = *****]	Access level value code 1	This function enables or disables, for each access level code, the main menu functions. Each level unlocks the functionality of the lower level.	---	[L1ACD]
13.2	[L2 code = *****]	Access level value code 2		---	[L2ACD]
13.3	[L3 code = *****]	Access level value code 3		---	[L3ACD]
13.4	[L4 code = *****]	Access level value code 4		---	[L4ACD]
13.5	[010.011.012.013]	Device IP Address	Device IP network address	AL3	[DIPAD]
13.6	[011.011.012.014]	Client IP Address	Client IP network address	AL3	[CIPAD]
13.7	[255.255.255.000]	Network Mask	Network mask	AL3	[NETMS]
13.8	[FW update]	Firmware Update	This function enables firmware update. The firmware can be uploaded to the SD card (name.file). MCP interface is activated by the command FWUPD = name.file	AL4	[FWUPD]

6.0 BIV (BUILT-IN VERIFICATION)

BIV, abbreviation of Built In Verificator, is available as option on the ProComm converter.

Note: For ProComm users who want to use BIV software, it can be downloaded from the McCrometer Web site under the category of Installation, Operation, and Maintenance Manuals.

<https://mccrometer.hachuat.com/asset-get.download-en.jsa?id=54942158006>

6.1 Functioning

The system test and store some functional parameters of sensor; the stored data shown any potential cause of sensor failure. Every hour the system performs a number of measures on the sensor and records them in a file called "STESTLOG.CSV", residing in the root directory of the SD memory on converter. The analysis of the data collected is left to special operating software on another device (PC, tablet, smart phone, etc.).

NOTICE: The sensor test can also be performed even with BIV off, but in this case it will be verified the overall functioning of the sensor (coil resistance, current and excitation current rise times within the generic limits that guarantee the operation). Instead, when BIV is active, the measures are more detailed and the measured values are tested by comparison with a set of parameters of the sensor detected at the installation.

6.2 Saving Reference Values (Characteristic Parameters)

After the sensor installation the following steps should be follow to set the reference values:

[SCTRF] : Set the Reference Temperature and Saving it.

[SRFDS] : Saving characteristic parameters

Saving parameters will be possible after 500 samples of measure. If you try to save the reference values before 500 measures, will be generated a specific error. (The time required is less than one minute). These functions are visible and active if the BIV function and SD card have been enabled.

6.3 Criteria and Internal Limits Values

The measured data are compared with reference values. The measured deviation shall be within the preset values. Here below the measured parameters:

- Temperature Coils (electrical resistance coils): compatible with the limits of the lining material;
- Current rise time: within % change in function of the resistance coils +10% (tolerance range)
- Electrical resistance between electrodes and common: $0.3 < \text{electrical resistance reference values} < 3.0$
- Electrical leakage current (isolation test): minus of 0.1 mA

If the values differ from these limits, it generates a coded alarm. The alarm remains active and visible on the display until the next test (max. 1 hour).

NOTE: the insulation test is done with a test voltage of about 25-30V for all electronics.

6.4 General Notes for the Activation of BIV

To enable the periodic testing of the sensor and create its data files the function Sensor Verify (menu 1 sensor) or via the MCP the function ASVFE = 1 shall be performed. This function can be activated even if the SD card and the BIV function is not active at the hardware level. In this case the file will be NOT created and also any alarm will be generated. In practice, in the absence of the necessary hardware/functions enabled, this function is useful to test the coils insulation.

6.5 ISOBIV Interface

To start the ISOBIV interface, wait till the connection with the ProComm will be realized.

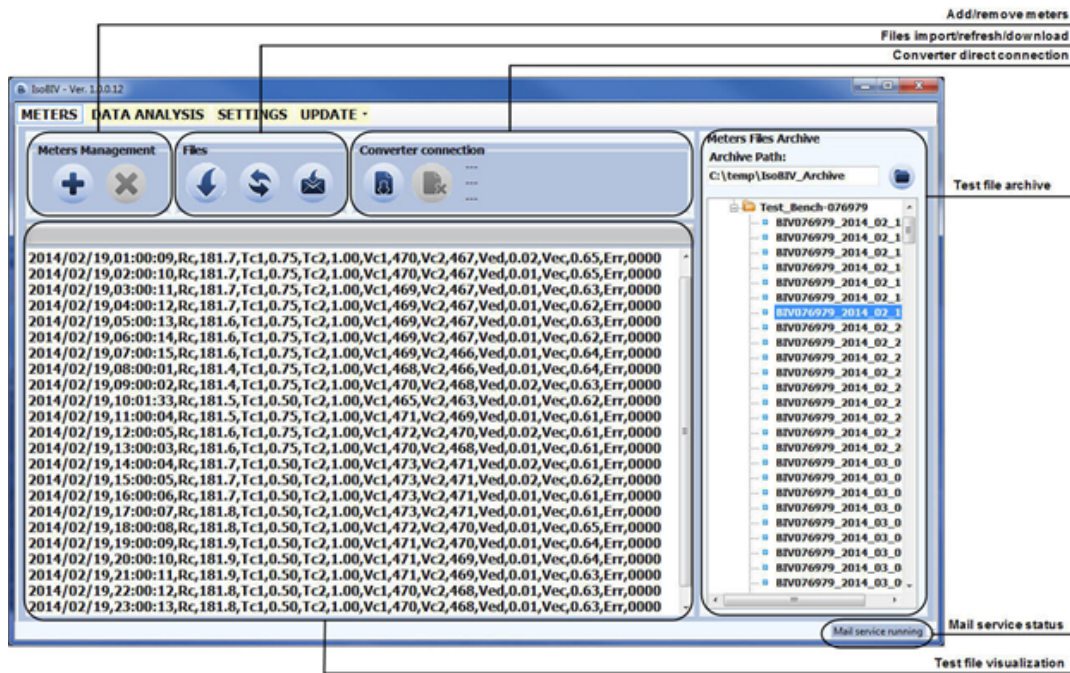

Software update: With a set of dedicated commands it is possible to connect to a HTTP server and to download automatically a new software release and/or command list. Once invoked, the process is performed automatically; the new software is checked, and in case of error the process is aborted and the instrument resumes the normal operation. All operation sequences are logged in the event logger.

For more information, consult the IsoBIV software manual.

7.0 ERROR CODES

The codes are in hexadecimal format, the meaning is given for each bit. There are several possible error simultaneous combinations (more bits active) then that will give the combined numerical codes.

CODE	ANOMALIES DESCRIPTION	ACTION TO TAKE	
0000	NO ERROR	---	
0001	SENSOR TEST INSULATION: Generator power too low	Contact customer service	
0002	SENSOR TEST INSULATION: Generator power too high		
0004	SENSOR TEST INSULATION: Phase 1 generator voltage too low		
0008	SENSOR TEST INSULATION: Phase 1 generator voltage too high		
0010	SENSOR TEST INSULATION: Phase 1 terminal voltage coils 1 too low		
0020	SENSOR TEST INSULATION: Phase 1 terminal voltage coils 2 too low		
0040	SENSOR TEST INSULATION: Phase 2 generator voltage too low		
0080	SENSOR TEST INSULATION: Phase 2 generator voltage too high		
0100	SENSOR TEST INSULATION: Phase 2 terminal voltage coils 1 too low		
0200	SENSOR TEST INSULATION: Phase 2 terminal voltage coils 2 too low		
0400	SENSOR TEST INSULATION: Insulation loss, current leakage out of tolerance		Check: <ul style="list-style-type: none"> • Wiring between sensor converter • Conditions of use • Set parameters If the problem, persists contact customer service
0800	TEST TEMPERATURE (RESISTANCE) COILS: Temperature (resistance) out of tolerance		
1000	TEST TIME GETTING ON CURRENT PHASE (A): Value out of tolerance		
2000	TEST TIME GETTING ON CURRENT PHASE (B): Value out of tolerance		
4000	TEST RESISTANCE INPUTS ELECTRODES: Input value 1 out of tolerance		
8000	TEST RESISTANCE INPUTS ELECTRODES: Input value 1 out of tolerance		

8.0 ALARM MESSAGES

MESSAGE	CAUSES	ACTION TO TAKE
NO ALARMS	All works regularly	---
[000] SYSTEM RESTART	---	---
[001] INTERNAL PS FAIL	Internal supply voltage error	Contact the service
[002] CLOCK NOT SET	System Clock not set	Set the system clock from the converter menu 13 (see also MCP function).
[003] SD CARD FAILURE	SD card not found or unreadable	Check and/or replace SD card
[005] F-RAM ERROR	Error writing / reading Flash-RAM	Contact customer service
[006] EXCITATION ERROR	The excitation of the sensor coils resulting from cable is interrupted	Check the connecting cables to the sensor
[007] SIGNAL ERROR	The measure is strongly effected by external noise or the cable connecting the converter to the sensor is broken.	Check the status of the cables connecting the sensor and the device grounding connectionsfor possible presence of noise sources.
[008] PIPE EMPTY	The measuring pipe is empty or the detection system has not been properly calibrated.	Check whether the pipe is empty, or repeat the empty pipe calibration procedure.
[009] FLOW>MAX+	The flow rate is higher than the maximum positive threshold set.	Check the maximum positive flow rate threshold set and the process conditions.
[010] FLOW>MAX-	The flow rate is higher than the maximum negative threshold set.	Check the maximum negative flow rate threshold set and the process conditions.
[011] FLOW<MIN+	The flow rate is lower than the minimum positive threshold set.	Check the minimum positive flow rate threshold set and the process conditions.
[012] FLOW<MIN-	The flow rate is lower than the minimum negative threshold set.	Check the minimum negative flow rate threshold set and the process conditions.
[013] FLOW>FULL SCALE+	The flow rate is higher than the full scale positive value set on the instrument.	Check the full scale positive value set on the instrument and the process conditions.
[014] FLOW>FULL SCALE-	The flow rate is higher than the full scale negative value set on the instrument.	Check the full scale negative value set on the instrument and the process conditions.
[015] PULSE1>RANGE	The pulse generation output 1 of the device is saturated and cannot generate the sufficient number of impulses.	Set a higher unit of volume or, if the connected counting device allows it, reduce the pulse duration value.
[016] PULSE2>RANGE	The pulse generation output 2 of the device is saturated and cannot generate the sufficient number of impulses.	Set a higher unit of volume or, if the connected counting device allows it, reduce the pulse duration value.
[017] CALIBR.ERROR	Calibration Error	Contact customer service
[018] SYSTEM FREQ.ERR	System Freq. Error	Contact customer service
[019] B.DATA NOT INIT	Uninitialized data system	Contact customer service
[020] FL.SENSOR ERROR	Flow rate sensor error	Contact customer service
[021] BATTERY LOW	(Rechargeable) battery depleted	Contact customer service to replace the battery

MESSAGE	CAUSES	ACTION TO TAKE
[022] BATTERY V>MAX	Battery voltage (rechargeable)> max. Allowed	Contact customer service to replace the battery
[023] BATTERY I>MAX	Battery charge current> max. allowed	Contact customer service to replace the battery
[024] MAIN PS V.ERR	Main supply voltage (+ 5V) out of tolerance.	Contact customer service
[025] USB VOLTAGE ERR	Voltage of USB connection out of tolerance.	Contact customer service
[026] SDC ALMOST FULL	SD card space <500 MB.	
[027] SDC FULL	SD card out of memory	SD card memory memory is full. You cannot save logger. Contact customer service to replace the SD card.
[028] BATT.TEMP.CRIT	The battery can not be charged. The temperature is out of range (detected temperature <0 C° or temperature >50°)	

9.0 SPECIFICATIONS

Physical Specifications

Electronic Housing	Diecast aluminum, powder coated enclosure w/ tamper resistant seal	
Converter Dimensions	Remote Mount:	Height: 7.3" (18.5 cm) Width: 8.5" (21.6 cm) Depth: 4.3" (10.9 cm)
	Meter Mount:	Height: 6.9" (17.5 cm) Width: 7.2" (18.25 cm) Depth: 6.2" (15.7 cm)
Power	AC Power:	100-240 VAC / 45-66 Hz (10 W)
	DC Power:	12-48 VDC (10 W)
Connection Options	<ul style="list-style-type: none"> • Compression gland seals for 0.24" to 0.47" diameter round cable • Conduit option: 1/2" NPT threaded connections 	
Galvanic Isolation	All inputs / outputs are galvanically isolated from power supply up to 500 V	
Conductivity	Minimum conductivity of 5µS/cm	

Performance and Operational Specifications

Accuracy	<ul style="list-style-type: none"> • ±0.5% from 1 f/s to max velocity, up to ±1% for 0.3 to 1 f/s • ±1% for reverse flow 		
Location	Indoor or outdoor use		
Operating and Storage Temperature	-4° to 140° F (-20° to 60° C)		
IP Rating	IP67 Die cast aluminum converter (only when connected using compression gland seals)		
Standard Outputs	Dual 4-20mA Outputs: Galvanically isolated and fully programmable for zero and full scale (0-21mA rangeability)		
	Two separate digital programmable outputs: open collector transistor usable for pulse, frequency, or alarm settings.		
Optional Outputs	<ul style="list-style-type: none"> • Volumetric Pulse • Flow Rate (Frequency) • Hardware Alarm • High/Low Flow Alarms • Empty Pipe • Directional Indication 	<ul style="list-style-type: none"> • Range Indication • Maximum switching voltage: 40 VDC • Maximum switching current: 100mA 	<ul style="list-style-type: none"> • Maximum switching frequency: 1250 Hz • Insulation from other secondary circuits: 500V
	<ul style="list-style-type: none"> • Modbus • HART 	<ul style="list-style-type: none"> • Smart Output™ (Sensus, Itron 6, Itron 9) 	<ul style="list-style-type: none"> • Datalogger • Built-in verification

Display and Measurement

Keyboard and Display	Can be used to access and change set-up parameters using six membrane keys and an LCD display		
Engineering Units	<ul style="list-style-type: none"> • Cubic Meter • Cubic Centimeter • Milliliter • Liter • Cubic Decimeter • Decaliter • Hectoliter • Cubic Inches 	<ul style="list-style-type: none"> • US Gallons • Imperial Gallons • Cubic Feet • Kilo Cubic Feet • Standard Barrel • Oil Barrel • US Kilogallon • Ten Thousands of Gallons 	<ul style="list-style-type: none"> • Imperial Kilogallon • Acre Feet • Megagallon • Imperial Megagallon • Hundred Cubic Feet • Megaliters

Other Specifications

Standard Model

- ISO 9001:2015 certified quality management system
- Certified by MET to UL 61010-1 / CSA C22.2 No. 61010-1
- Certified to NSF / ANSI Standards*

HL Model

- ISO 9001:2015 certified quality management system
- Certified by MET: Safety: UL61010-1 / CSA C22.2 No. 61010-1, Third Edition: Safety of Electrical Equipment For Measurement, Control, and Laboratory Use
- Certified by MET: Standards: ANSI / ISA12.12.01 / CSA C22.2 No. 213, Nonincendive Electrical Equipment
 - Class I and II, Division 2
 - Class III, Divisions 1 and 2 Hazardous (Classified) Locations
- Certified to NSF / ANSI Standards*



IMPORTANT

Electrical safety certifications above do not apply to model 282L Single Point Insertion (SPI Mag) Electromagnetic Flow Meter.



IMPORTANT

Refer to certification requirements. Do not substitute components.



IMPORTANT

The ProComm converter, models PC-RA1-HL series and PC-MA1-HL series have no user serviceable parts.

10.0 DIMENSIONS

Meter Mount Converter Dimensions

Height 6.9" (20.1 cm)
Width 7.2" (18.3 cm)
Depth 6.2" (15.7 cm)

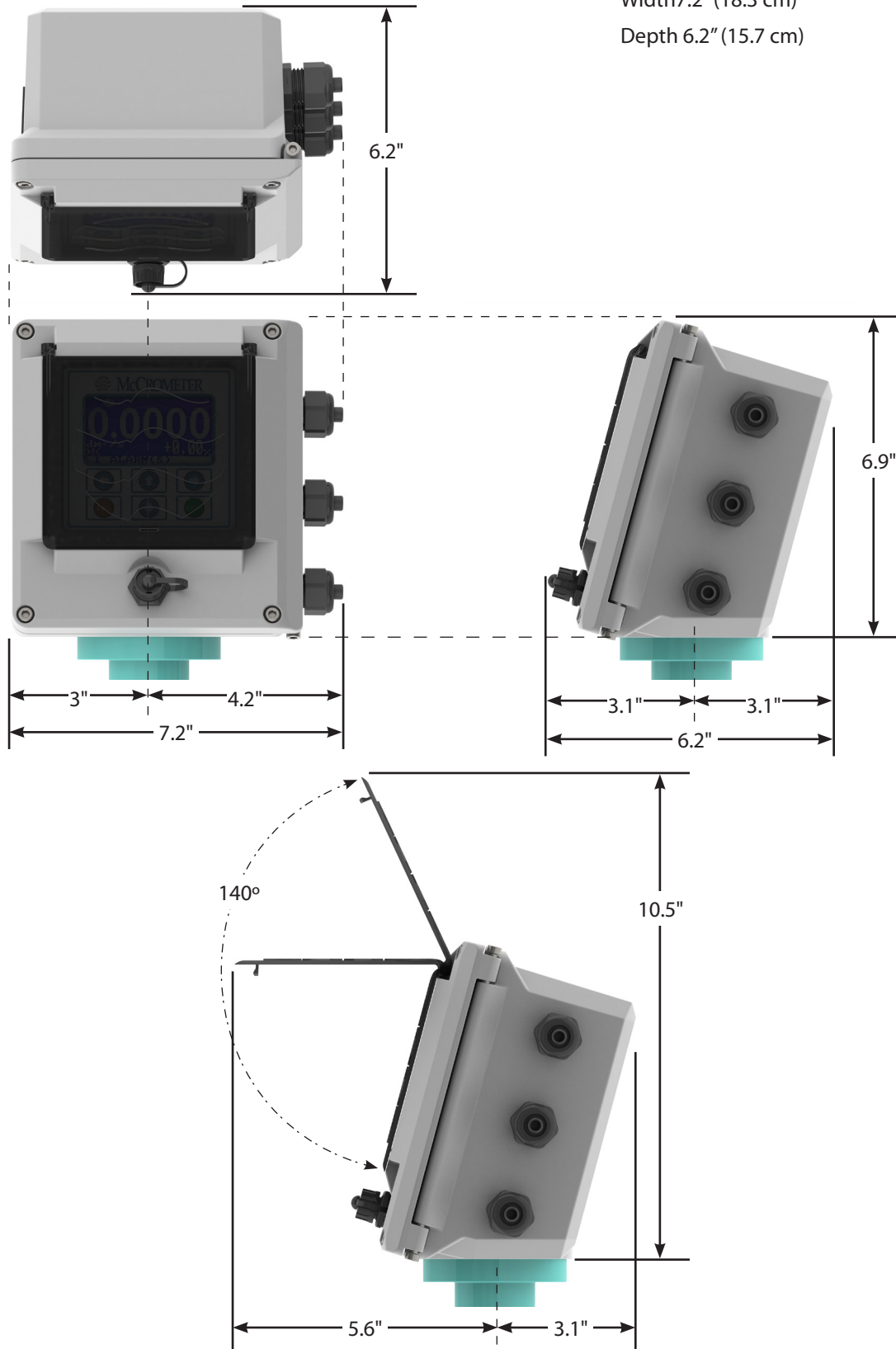

Remote Mount Converter Dimensions

Height 7.3" (18.5 cm)
Width 8.5" (21.6 cm)
Depth 4.3" (10.9 cm)

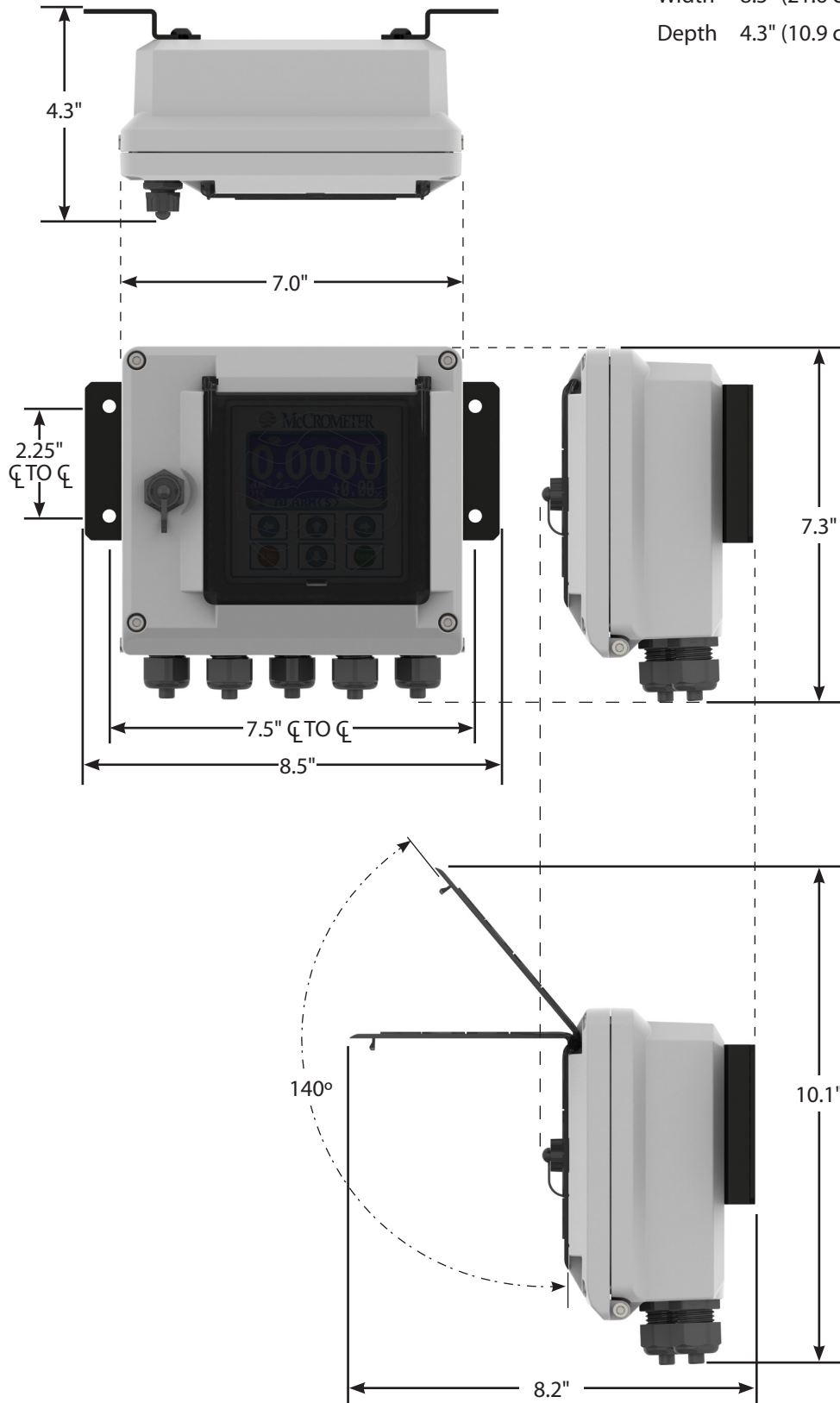

11.0 RETURNING A UNIT FOR REPAIR

If the unit needs to be returned to the factory for repair, please do the following:

- Prior to calling for a return authorization number, determine the model number, serial number (located inside the front panel of converter), and reason for return.
- Contact McCrometer Customer Service Department and ask for a Return Authorization (RA) number.
 - Telephone: 1-800-220-2279
 - Email: customerservice@mccrometer.com
- Ship the meter in the original packaging, if possible. Do not ship manuals, power cords, or other parts with your unit unless required for repair.
- Please make sure the meter is clean and free from foreign debris prior to shipping.
- Write the RA number on the outside of the shipping box. All return shipments should be insured.
- Address all shipments to:
 - McCrometer, Inc.
 - RMA #
 - 3255 W. Stetson Avenue
 - Hemet, CA 92545

12.0 TROUBLESHOOTING GUIDE



WARNING!

Ensure device is disconnected or circuit breaker is open per the requirements of IEC 60947-1 and IEC 60947-3 before opening the opening the converter.

Problem	Troubleshooting Steps
Not getting expected 4-20mA output	<ul style="list-style-type: none"> • Ensure the wiring is firmly connected on the 4-20mA output terminals • Verify resistor removed from terminal block • Verify the FS1 setting in the main menu is set to the correct value, matches PLC/SCADA value • Measure output on the 4-20mA terminals and compare it to the calculated current value
Curr. Loop Open Alarm	<ul style="list-style-type: none"> • Ensure the wiring is firmly connected on the 4-20mA output terminals • If the 4-20mA output is not being used, ensure the 4-20mA terminals have a load resistor installed • Remove the wires from the 4-20mA terminals and measure the current output direct
Excitation Fail (0800) Alarm	<ul style="list-style-type: none"> • Ensure the wiring is firmly connected • Disconnect the coil wires from the converter and check their resistance with a standard multi-meter. Contact the factory for the proper value for the sensor.
Noisy Input Alarm	<ul style="list-style-type: none"> • Verify the converter ground is to earth ground • Check for damaged cable between the sensor and converter
Empty Pipe Alarm	<ul style="list-style-type: none"> • Increase threshold to 250 kΩ. • Confirm the pipe is full. If pipe is always full, turn off EP Detect • Check that sensor is properly grounded • Conduct a bucket test to confirm the EP Threshold value is set correctly. Consult the factory for assistance. • Check for damaged cable between the sensor and converter
Unstable Flow Readings	<ul style="list-style-type: none"> • Check installation straight run requirements are met • Check grounding connections • Check power circuit. What other devices are on the circuit • Install dedicated ground circuit
Menu Not Accessible	<ul style="list-style-type: none"> • Confirm the password being used is 400000
Rate Of Flow Report Is Not As Expected	<ul style="list-style-type: none"> • Confirm the unit is programmed correctly by requesting a program setting report from the factory.

WARRANTY

McCrometer warrants that this product will be free from defects in material and workmanship for a period 12 months from the date the equipment was first installed, but in no event longer than 18 months from the date the equipment was first shipped by McCrometer. Repairs shall be warranted for 12 months or, if the repair is performed under this warranty, for the remainder of the original warranty period, whichever is less.

Buyer shall report any claimed defect in writing to McCrometer immediately upon discovery and in any event, within the warranty period. McCrometer shall, at its sole option, repair the equipment or furnish replacement equipment or parts thereof, at the original delivery point.

McCrometer shall not be liable for costs of removal, reinstallation, or gaining access. If Buyer or others repair, replace, or adjust equipment or parts without McCrometer prior written approval, McCrometer is relieved of any further obligation to Buyer under this Article with respect to such equipment.

No equipment furnished by McCrometer shall be deemed to be defective by reason of normal wear and tear, failure to resist erosive or corrosive action of any fluid or gas (unless otherwise specified in Quotations/ Purchase Order Specifications), Buyer's direct or indirect failure (or the failure of its agents or contractors) to properly store, install, operate, or maintain the equipment in accordance with good industry practices or specific recommendations of McCrometer, or Buyer's failure to provide complete and accurate information to McCrometer concerning the operational application of the equipment.

THE FOREGOING LIMITED WARRANTIES WITH RESPECT TO EQUIPMENT AND PRODUCTS ARE EXCLUSIVE AND IN LIEU OF ANY AND ALL OTHER WARRANTIES OF QUALITY OR PERFORMANCE, EXPRESS, IMPLIED OR STATUTORY, INCLUDING, WITHOUT LIMITATION, ANY AND ALL WARRANTIES OF MERCHANTABILITY OR FITNESS OF SAID EQUIPMENT AND PRODUCTS FOR ANY PARTICULAR PURPOSE.

MCCROMETER DISCLAIMS ANY WARRANTY, WHETHER EXPRESS OR IMPLIED, REGARDING THE SUITABILITY OF PRODUCTS AND EQUIPMENT SUPPLIED PURSUANT TO ANY PURCHASE ORDER FOR INSTALLATION IN ANY PARTICULAR SYSTEM OF SYSTEMS. MCCROMETER MAKES NO WARRANTY OF ANY KIND WITH RESPECT TO ANY SERVICES PERFORMED BY MCCROMETER OR ITS AGENTS PURSUANT TO ANY QUOTATION.

Purchaser's sole remedy and manufacturer's sole obligation for alleged product failure, whether under warranty claim or otherwise, shall be the aforesaid obligation of manufacturer to repair or replace products returned within twenty-four months after date of original shipment. The manufacturer shall not be liable for, and the purchaser assumes and agrees to indemnify and save harmless the manufacturer in respect to, any loss or damage that may arise through the use by the purchaser of any of the manufacturer's products.

McCrometer does not authorize any person or entity (including, without limitation, McCrometer agents and employees) to make any representations (verbal or written) contrary to the terms of this limited warranty or its exclusions. Such terms of this limited warranty and its exclusions can only be effectively modified in writing and only by the President of McCrometer.

OTHER McCROMETER PRODUCTS INCLUDE:

Propeller Flow Meters



Differential Pressure Flow Meters



Magnetic Flow Meters



Connected Solutions



Copyright © 2022 McCrometer, Inc. All printed material should not be changed or altered without permission of McCrometer. Any published pricing, technical data, and instructions are subject to change without notice. Contact your McCrometer representative for current pricing, technical data, and instructions.

3255 WEST STETSON AVENUE • HEMET, CALIFORNIA 92545 USA
TEL: 951-652-6811 • 800-220-2279 • FAX: 951-652-3078
www.mccrometer.com

